



**Bray**<sup>®</sup>

**SERIES 3A / 3AH** Double Flanged  
2" - 20" (50mm-500mm)

# **BUTTERFLY VALVES**

RESILIENT SEATED

# FEATURES

Bray Controls is proud to offer a high quality line of flanged butterfly valves to meet the requirements of today's market. Combining years of field application experience, research and development, Bray has designed many unique features in the Series 3A/3AH not previously available. The results are longer service life, greater reliability, ease of parts replacement and interchangeability of components.

Bray's Series 3A/3AH valves are a double flanged design which can be used for dead-end service. All Bray valves are tested to 110% of full pressure rating before shipment.

A major design advantage of Bray valve product lines is international compatibility. The same valve is compatible with most world flange standards – ASME Class 125/150, BS 10 Tables D and E, BS 4504 NP 10/16, DIN ND 10/16, AS 2129 and JIS10. In addition, the valves are designed to comply with ISO 5752 - Table 2 (short pattern) face-to-face and ISO 5211 actuator mounting flanges. Therefore, one valve design can be used in many different world markets.

Bray interchangeability and compatibility offers the best in uniformity of product line and low-cost performance in the industry today.

## PRIMARY AND SECONDARY SEALS

The primary seal is achieved by pre-loaded contact of spherically machined hand polished disc hubs with unique molded seat flat surfaces. This sealing method isolates the flowing media from the stem and body material at all angles of valve disc seating. A secondary seal is achieved by an interference fit of the stem and seat hole diameters.

## STEM RETAINING ASSEMBLY

The stem is retained in the body by means of a unique Stainless Steel "Spirolox<sup>®</sup>" retaining ring, a thrust washer and two C-rings, manufactured from brass as standard, stainless steel upon request. The retaining ring may be easily removed with a standard hand tool. The stem retaining assembly prevents unintentional removal of the stem during field service.

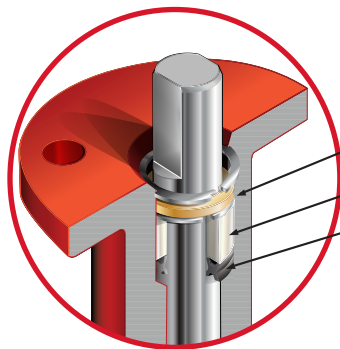

**STEM RETAINING ASSEMBLY**  
**STEM BUSHING**  
**STEM SEAL**

**STEM BUSHING** Non-corrosive, heavy duty acetal bushing absorbs actuator side thrusts.

**STEM SEAL** Double "U" cup seal design is self-adjusting, gives positive sealing in both directions, and prevents external substances from entering the stem bore.

**EXTENDED NECK** Extended neck length allows for 2" of piping insulation and is easily accessible for mounting actuators.

## DISC

Spherically machined and hand polished to provide a bubble-tight shut off, minimum torque, and longer seat life. Standard material is Nylon 11 coated ductile Iron. Other materials available on request.

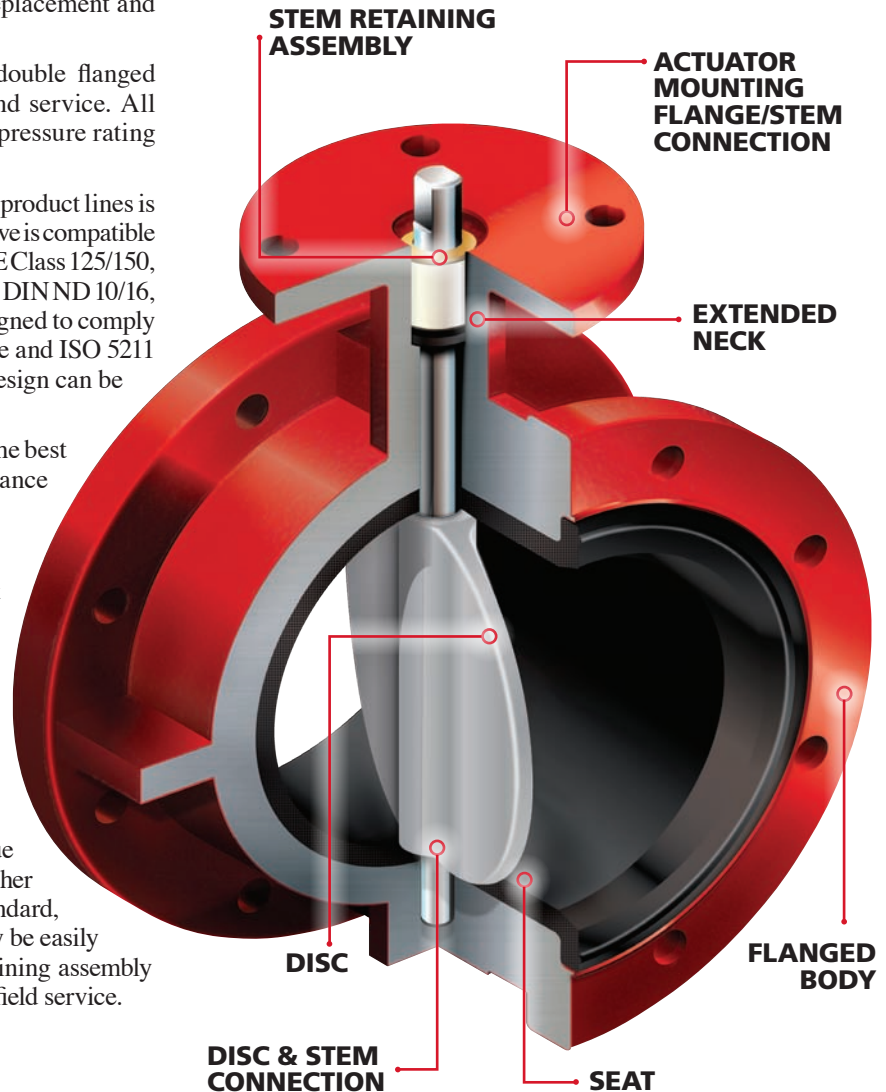

## NYLON 11 COATING

A thermoplastic coating produced from a vegetable base and is USDA Approved, as well as, certified to ASME/NSF61 for water service. It is inert to fungus growth and mold, has excellent resistance to impact and provides a very low coefficient of friction.

Nylon 11 also has superior corrosion resistance and has been used successfully in many applications such as water, cement, food and seawater. Bray's Nylon 11 coating has been salt spray tested in excess of 2000 hours and used in seawater immersion service for over 25 years without any deterioration of the coating resulting in no corrosion to the coated metal components. As a result, the use of Nylon 11 in seawater with elevated chloride levels between 30,000 - 40,000 ppm continues to increase.

"Spirolox<sup>®</sup>" designation is a registered trademark of Kaydon Ring and Seal, Inc.

# SELECTION DATA

## FLANGE REQUIREMENTS

Bray valves are designed for installation between ASME Class 125/150 lb. weld-neck or slip-on flanges, BS 10 Tables D & E, BS 4504 NP 10/16, DIN ND 10/16, AS 2129 and JIS 10, either flat faced or raised faced. While weld-neck flanges are recommended, Bray has specifically designed its valve

seat to work with slip-on flanges, thus eliminating common failures of other butterfly valve designs. When using raised face flanges be sure to properly align valve and flange. Type C stub-end flanges are not recommended.

## PRESSURE RATINGS

For Bi-directional Bubble-Tight Shut-Off and Dead-End Applications

### SERIES 3A

| Size Range           | Standard Disc       | Reduced Disc*     |
|----------------------|---------------------|-------------------|
| 2"-12" (50-300 mm)   | 175 psig (12.1 bar) | 50 psig (3.5 bar) |
| 14"-20" (350-500 mm) | 150 psig (10.3 bar) | 50 psig (3.5 bar) |

### SERIES 3AH

| Size Range         | Standard Disc       | Reduced Disc* |
|--------------------|---------------------|---------------|
| 2"-20" (50-500 mm) | 250 psig (17.2 bar) | NA NA         |

\*For low pressure application, Bray offers a standard reduced disc diameter to decrease seating torques and to extend seat life, thus increasing the valve's performance and reducing actuator costs for the customer consult factory.

## VELOCITY LIMITS FOR ON-OFF SERVICE

Fluids – 30 ft/sec (9 m/s)      Gases – 175 ft/sec (54 m/s)



## DIMENSIONS SERIES 3A/3AH - ins (mm)

| Valve Size<br>ins<br>(mm) | A              | B             | C              | D*             | E              | F             | Top Plate Drilling |           |               | G            | H           | J            | K             | L            | Flange Bolting Data |           |                |
|---------------------------|----------------|---------------|----------------|----------------|----------------|---------------|--------------------|-----------|---------------|--------------|-------------|--------------|---------------|--------------|---------------------|-----------|----------------|
|                           |                |               |                |                |                |               | Bolt Circle        | No. Holes | Hole Dia.     |              |             |              |               |              | Bolt Circle         | No. Holes | Threads UNC-2B |
| 2<br>(50)                 | 6.50<br>(165)  | 4.25<br>(108) | 2.00<br>(51)   | 2.84<br>(72)   | 5.50<br>(140)  | 3.54<br>(90)  | 2.76<br>(70)       | 4         | .39<br>(9.9)  | .55<br>(14)  | .39<br>(10) | 1.25<br>(32) | X             | .79<br>(20)  | 4.75<br>(121)       | 4         | 5/8-11         |
| 2.5<br>(65)               | 7.28<br>(185)  | 4.41<br>(112) | 2.50<br>(64)   | 3.34<br>(85)   | 6.00<br>(152)  | 3.54<br>(90)  | 2.76<br>(70)       | 4         | .39<br>(9.9)  | .55<br>(14)  | .39<br>(10) | 1.25<br>(32) | X             | .79<br>(20)  | 5.50<br>(140)       | 4         | 5/8-11         |
| 3<br>(80)                 | 7.87<br>(200)  | 4.49<br>(114) | 3.00<br>(76)   | 4.03<br>(102)  | 6.25<br>(159)  | 3.54<br>(90)  | 2.76<br>(70)       | 4         | .39<br>(9.9)  | .55<br>(14)  | .39<br>(10) | 1.25<br>(32) | X             | .87<br>(22)  | 6.00<br>(152)       | 4         | 5/8-11         |
| 4<br>(100)                | 8.66<br>(220)  | 5.00<br>(127) | 4.00<br>(102)  | 5.16<br>(131)  | 7.00<br>(178)  | 3.54<br>(90)  | 2.76<br>(70)       | 4         | .39<br>(9.9)  | .63<br>(16)  | .43<br>(11) | 1.25<br>(32) | X             | .95<br>(24)  | 7.50<br>(191)       | 8         | 5/8-11         |
| 5<br>(125)                | 9.84<br>(250)  | 5.51<br>(140) | 5.00<br>(127)  | 6.16<br>(156)  | 7.50<br>(190)  | 3.54<br>(90)  | 2.76<br>(70)       | 4         | .39<br>(9.9)  | .75<br>(19)  | .51<br>(13) | 1.25<br>(32) | X             | 1.03<br>(26) | 8.50<br>(216)       | 8         | 3/4-10         |
| 6<br>(150)                | 11.22<br>(285) | 5.51<br>(140) | 5.75<br>(146)  | 7.02<br>(178)  | 8.00<br>(203)  | 3.54<br>(90)  | 2.76<br>(70)       | 4         | .39<br>(9.9)  | .75<br>(19)  | .51<br>(13) | 1.25<br>(32) | 1.78<br>(45)  | 1.03<br>(26) | 9.50<br>(241)       | 8         | 3/4-10         |
| 8<br>(200)                | 13.50<br>(343) | 5.98<br>(152) | 7.75<br>(197)  | 9.47<br>(241)  | 9.50<br>(241)  | 5.91<br>(150) | 4.92<br>(125)      | 4         | .57<br>(14.5) | .87<br>(22)  | .63<br>(16) | 1.25<br>(32) | 5.00<br>(127) | 1.18<br>(30) | 11.75<br>(298)      | 8         | 3/4-10         |
| 10<br>(250)               | 15.94<br>(405) | 6.50<br>(165) | 9.75<br>(248)  | 11.47<br>(291) | 10.75<br>(273) | 5.91<br>(150) | 4.92<br>(125)      | 4         | .57<br>(14.5) | 1.18<br>(30) | .87<br>(22) | 2.00<br>(51) | 7.35<br>(187) | 1.26<br>(32) | 14.25<br>(362)      | 12        | 7/8-9          |
| 12<br>(300)               | 19.00<br>(483) | 7.01<br>(178) | 11.75<br>(298) | 13.47<br>(342) | 12.25<br>(311) | 5.91<br>(150) | 4.92<br>(125)      | 4         | .57<br>(14.5) | 1.18<br>(30) | .87<br>(22) | 2.00<br>(51) | 9.53<br>(242) | 1.26<br>(32) | 17.00<br>(432)      | 12        | 7/8-9          |

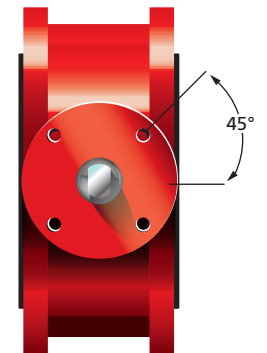

| Valve Size<br>ins<br>(mm) | A              | B             | C              | D*             | E              | F             | Top Plate Drilling |           |             | G            | Key Size           | J            | K              | L            | Flange Bolting Data |           |                |
|---------------------------|----------------|---------------|----------------|----------------|----------------|---------------|--------------------|-----------|-------------|--------------|--------------------|--------------|----------------|--------------|---------------------|-----------|----------------|
|                           |                |               |                |                |                |               | Bolt Circle        | No. Holes | Hole Dia.   |              |                    |              |                |              | Bolt Circle         | No. Holes | Threads UNC-2B |
| 14<br>(350)               | 21.00<br>(533) | 7.48<br>(190) | 13.25<br>(337) | 15.28<br>(388) | 13.62<br>(346) | 5.91<br>(150) | 4.92<br>(125)      | 4         | .57<br>(14) | 1.38<br>(35) | .39x.39<br>(10x10) | 2.00<br>(51) | 11.07<br>(281) | 1.42<br>(36) | 18.75<br>(476)      | 12        | 1-8            |
| 16<br>(400)               | 23.50<br>(597) | 8.51<br>(216) | 15.25<br>(387) | 17.41<br>(442) | 14.75<br>(375) | 5.91<br>(150) | 4.92<br>(125)      | 4         | .57<br>(14) | 1.38<br>(35) | .39x.39<br>(10x10) | 2.00<br>(51) | 12.81<br>(325) | 1.50<br>(38) | 21.25<br>(540)      | 16        | 1-8            |
| 18<br>(450)               | 25.20<br>(640) | 8.74<br>(222) | 17.25<br>(438) | 19.47<br>(495) | 16.00<br>(406) | 8.27<br>(210) | 6.50<br>(165)      | 4         | .81<br>(21) | 1.97<br>(50) | .47x.39<br>(12x10) | 2.50<br>(64) | 15.02<br>(381) | 1.65<br>(42) | 22.75<br>(578)      | 16        | 11/8-7         |
| 20<br>(500)               | 28.15<br>(715) | 9.02<br>(229) | 19.25<br>(489) | 21.59<br>(548) | 17.25<br>(438) | 8.27<br>(210) | 6.50<br>(165)      | 4         | .81<br>(21) | 1.97<br>(50) | .47x.39<br>(12x10) | 2.50<br>(64) | 17.15<br>(436) | 1.65<br>(42) | 25.00<br>(635)      | 20        | 11/8-7         |

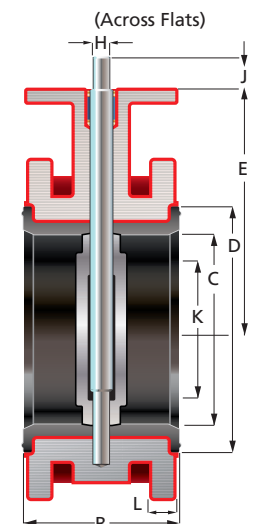

Note: K dim is disc chordal dimension at valve face

\* Flat Faced Flange Available - Contact factory for dimensional information



## RECOMMENDED SPECIFICATIONS FOR BRAY SERIES 3A/3AH SHALL BE:

- Polyester coated, cast iron, double flanged bodies.
- Complies with ISO 5752 - Table 2 (short pattern) face-to-face
- With flange locating holes that meet ASME Class 125/150 (or BS 10 Tables D & E, BS 4504 NP 10/16, DIN ND 10/16, AS 2129 and JIS 10) drillings.
- Through-stem direct drive double "D" design requiring no disc screws or pins to connect stem to disc with no possible leak paths in disc/stem connection.
- Stem mechanically retained in body neck and no part of stem or body exposed to line media.
- Seat design with primary hub seal and a molded O-ring suitable for weld-neck and slip-on flanges. Seat totally encapsulates the body with no flange gaskets required.
- Spherically machined, hand polished disc edge and hub for minimum torque and maximum sealing capability.
- Equipped with non-corrosive bushing and self-adjusting stem seal.
- Bi-directional and tested to 110% of full rating.
- Bi-directional dead-end pressure rating:  
Series 3A 2"-12" (50-300 mm) - 175 psi (12.2 bar)  
14"-20" (350-500 mm) - 150 psi (10.3 bar)  
Series 3AH 2"-20" (50-500 mm) - 250 psi (17.2 bar)
- No field adjustment necessary to maintain optimum field performance.
- The valve shall be Bray Series 3A Double Flanged.
- Valves available with CE marking.

## MATERIALS SELECTION 2"-20" (50mm-500mm)

### BODY:

- Cast Iron ASTM A126 Class B
- Ductile Iron ASTM A536
- Cast Steel ASTM A216 WCB

### SEAT:

- Aerospace - Bonded EPDM
- Aerospace - Bonded BUNA-N (NBR)
- Aerospace - Bonded FKM\*

### STEM:

- 416 Stainless Steel ASTM A582 Type 416
- 304 Stainless Steel ASTM A276 Type 304
- 316 Stainless Steel ASTM A276 Type 316
- Monel

### DISC:

- Aluminum Bronze ASTM B148-954
- Nylon 11 Coated Ductile Iron  
ASTM A536 Gr. 65-45-12
- 316 Stainless Steel ASTM A351 CF8M
- 304 Stainless Steel ASTM A351 CF8



**Additional materials are available. Please consult your Bray representative.**

\*FKM is the ASTM D1418 designation for Fluorinated Hydrocarbon Elastomers (also called Fluoroelastomers).

## TEMPERATURE RANGE OF SEATS

| Type   | Maximum        | Minimum       |
|--------|----------------|---------------|
| EPDM   | +250°F (121°C) | -40°F (-40°C) |
| Buna-N | +212°F (100°C) | 0°F (-18°C)   |
| FKM*   | +400°F (204°C) | 0°F (-18°C)   |

## WEIGHTS

| Valve Size |       | lbs | (Kg)  |
|------------|-------|-----|-------|
| ins        | (mm)  |     |       |
| 2          | (50)  | 22  | (10)  |
| 2.5        | (65)  | 24  | (11)  |
| 3          | (80)  | 28  | (13)  |
| 4          | (100) | 35  | (16)  |
| 5          | (125) | 45  | (21)  |
| 6          | (150) | 59  | (27)  |
| 8          | (200) | 70  | (32)  |
| 10         | (250) | 132 | (60)  |
| 12         | (300) | 178 | (81)  |
| 14         | (350) | 258 | (117) |
| 16         | (400) | 318 | (144) |
| 18         | (450) | 459 | (208) |
| 20         | (500) | 534 | (242) |

## COMPONENTS

| No. | Qty. | Description    |
|-----|------|----------------|
| 1   | 1    | Body           |
| 2   | 1    | Seat           |
| 3   | 1    | Disc           |
| 4   | 1    | Stem           |
| 5   | 1    | Stem Seal      |
| 6   | 1    | Stem Bushing   |
| 7   | 2    | Stem Retainer  |
| 8   | 1    | Thrust Washer  |
| 9   | 1    | Retaining Ring |

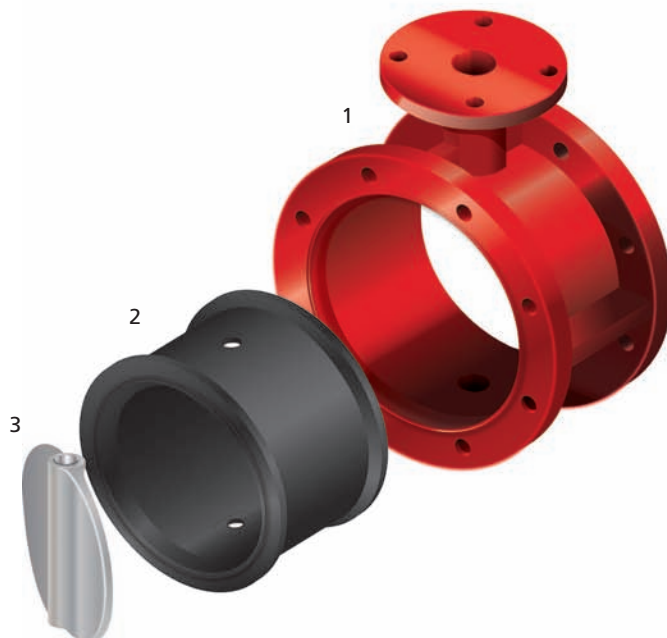

## BODY

One-piece double flanged body. All bodies can be drilled to be compatible with ASME 125/150, PN10 or other international flange standards. The Series 3A/3AH may be bolted to allow downstream flange removal or cross-bolted for maximum resistance to line stresses.

## DISC AND STEM CONNECTION

Features a high-strength through stem design. The close tolerance, double “D” connection that drives the valve disc is an exclusive feature of the Bray valve. This internal connection eliminates the need for exposed disc-stem fasteners such as disc screws and taper pins which are exposed to the line media and potential corrosion leading to the creation of leak paths and disc-stem connection failures.

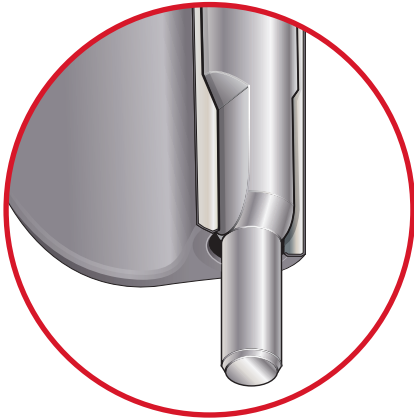

Disc screws or taper pins, due to wear and corrosion, often require difficult machining for disassembly. Disassembly of the Bray stem is simply a matter of pulling the stem out of the disc. Without fasteners obstructing the line flow, the  $C_v$  values are higher than many other valves, turbulence is reduced, and pressure recovery is increased.

## ACTUATOR MOUNTING FLANGE AND STEM CONNECTION

Universally designed to ISO 5211 for direct mounting of Bray power actuators and manual operators. The stem ends and top mounting flange are standardized for interchangeability with Bray actuators. Stem to actuator connections are double “D” for sizes 2"-12" and keyed for sizes 14" - 20".

## BRAY SEAT DESIGN

Brays seat design, aerospace-bonded to the body, is designed to seal with slip-on or weld-neck flanges. Seat totally encases the valve interior to isolate the line media from the body.

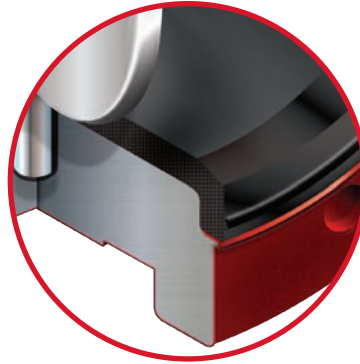

## POLYESTER BODY COATING

Bray's standard product offers valve bodies with a polyester coating. This coating provides excellent corrosion, abrasion and impact resistance.

**NOTE: Nylon 11 coating is available as an option for valve bodies where environmental protection is required.**



## $C_v$ VALUES—VALVE SIZING COEFFICIENT

| Valve Size<br>ins (mm) | Disc Position-Degrees |       |       |      |      |      |      |     |     |
|------------------------|-----------------------|-------|-------|------|------|------|------|-----|-----|
|                        | 90°                   | 80°   | 70°   | 60°  | 50°  | 40°  | 30°  | 20° | 10° |
| 2 (50)                 | 144                   | 114   | 84    | 61   | 43   | 27   | 16   | 7   | 1   |
| 2.5 (65)               | 282                   | 223   | 163   | 107  | 67   | 43   | 24   | 11  | 1.5 |
| 3 (80)                 | 461                   | 364   | 267   | 154  | 96   | 61   | 35   | 15  | 2   |
| 4 (100)                | 841                   | 701   | 496   | 274  | 171  | 109  | 62   | 27  | 3   |
| 5 (125)                | 1376                  | 1146  | 775   | 428  | 268  | 170  | 98   | 43  | 5   |
| 6 (150)                | 1850                  | 1542  | 1025  | 567  | 354  | 225  | 129  | 56  | 6   |
| 8 (200)                | 3316                  | 2842  | 1862  | 1081 | 680  | 421  | 241  | 102 | 12  |
| 10 (250)               | 5430                  | 4525  | 2948  | 1710 | 1076 | 667  | 382  | 162 | 19  |
| 12 (300)               | 8077                  | 6731  | 4393  | 2563 | 1594 | 1005 | 555  | 235 | 27  |
| 14 (350)               | 10538                 | 8874  | 5939  | 3384 | 2149 | 1320 | 756  | 299 | 34  |
| 16 (400)               | 13966                 | 11761 | 7867  | 4483 | 2847 | 1749 | 1001 | 397 | 45  |
| 18 (450)               | 17214                 | 14496 | 10065 | 5736 | 3643 | 2237 | 1281 | 507 | 58  |
| 20 (500)               | 22339                 | 18812 | 12535 | 7144 | 4536 | 2786 | 1595 | 632 | 72  |

$C_v$  is defined as the volume of water in USGPM that will flow through a given restriction or valve opening with a pressure drop of one (1) psi at room temperature.

## 3SA EXPECTED SEATING/UNSEATING TORQUES - Lb-Ins (Nm)\*

| Valve Size<br>ins (mm) | Full-Rated Pressure Valves - psi (bar) |              |              |            |              |              |              |              | Reduced Disc Diameter |              |
|------------------------|--|--------------|--------------|------------|--------------|--------------|--------------|--------------|-----------------------|--------------|
|                        | 50 (3)                                 | 100 (7)      | 150 (10)     | 175 (12)   | 200 (14)     | 250 (17)     | 300 (21)     | 350 (24)     | 50 (3)                | 300 (21)     |
| 2 (50)                 | 125 (14)                               | 130 (15)     | 135 (15)     | 140 (16)   | 125 (14)     | 125 (14)     | 125 (14)     | 125 (14)     | 125 (14)              | 125 (14)     |
| 2.5 (65)               | 195 (22)                               | 205 (23)     | 215 (24)     | 220 (25)   | 195 (22)     | 195 (22)     | 195 (22)     | 195 (22)     | 195 (22)              | 195 (22)     |
| 3 (80)                 | 260 (29)                               | 275 (31)     | 290 (33)     | 297 (34)   | 260 (29)     | 260 (29)     | 260 (29)     | 260 (29)     | 260 (29)              | 260 (29)     |
| 4 (100)                | 400 (45)                               | 425 (48)     | 450 (51)     | 462 (52)   | 400 (45)     | 400 (45)     | 400 (45)     | 400 (45)     | 400 (45)              | 400 (45)     |
| 5 (125)                | 615 (69)                               | 670 (76)     | 725 (82)     | 755 (85)   | 615 (69)     | 615 (69)     | 615 (69)     | 615 (69)     | 615 (69)              | 615 (69)     |
| 6 (150)                | 783 (88)                               | 871 (98)     | 953 (108)    | 1003 (113) | 783 (88)     | 783 (88)     | 783 (88)     | 783 (88)     | 783 (88)              | 783 (88)     |
| 8 (200)                | 1475 (167)                             | 1650 (186)   | 1825 (206)   | 1915 (216) | 1475 (167)   | 1475 (167)   | 1475 (167)   | 1475 (167)   | 1475 (167)            | 1475 (167)   |
| 10 (250)               | 2240 (253)                             | 2520 (285)   | 2800 (316)   | 2940 (332) | 2240 (253)   | 2240 (253)   | 2240 (253)   | 2240 (253)   | 2240 (253)            | 2240 (253)   |
| 12 (300)               | 3420 (386)                             | 3870 (437)   | 4320 (488)   | 4545 (514) | 3420 (386)   | 3420 (386)   | 3420 (386)   | 3420 (386)   | 3420 (386)            | 3420 (386)   |
| 14 (350)               | 4950 (559)                             | 5700 (644)   | 6450 (729)   | -          | 4950 (559)   | 4950 (559)   | 4950 (559)   | 4950 (559)   | 4950 (559)            | 4950 (559)   |
| 16 (400)               | 6400 (723)                             | 7700 (870)   | 9000 (1017)  | -          | 6400 (723)   | 6400 (723)   | 6400 (723)   | 6400 (723)   | 6400 (723)            | 6400 (723)   |
| 18 (450)               | 7850 (887)                             | 9850 (1113)  | 11850 (1339) | -          | 7850 (887)   | 7850 (887)   | 7850 (887)   | 7850 (887)   | 7850 (887)            | 7850 (887)   |
| 20 (500)               | 10300 (1164)                           | 12900 (1458) | 15500 (1752) | -          | 10300 (1164) | 10300 (1164) | 10300 (1164) | 10300 (1164) | 10300 (1164)          | 10300 (1164) |

\*Consult factory for Series 3AH Seating/Unseating torques



**Bray International - Houston, Texas**



**Bray China**



**Flow-Tek USA**



**Bray Canada**



**Bray United Kingdom**



**Flow-Tek China**



**Bray Mexico**



**Bray Brazil**



**Bray Benelux**



**Bray Pacific (Australia)**



**Bray Chile**



**Ritepro Canada**



**Bray Germany**



**Bray Poland**

All statements, technical information, and recommendations in this bulletin are for general use only. Consult Bray representatives or factory for the specific requirements and material selection for your intended application. The right to change or modify product design or product without prior notice is reserved.

Patents issued and applied for worldwide.



A Division of BRAY INTERNATIONAL, Inc.  
 13333 Westland East Blvd. Houston, Texas 77041  
 281.894.5454 FAX 281.894.9499 www.bray.com

Bray® is a registered trademark of BRAY INTERNATIONAL, Inc.

© 2010 Bray International. All rights reserved.  
 B-1047\_EL\_S3A-3AH\_2010-01