

MX1N Steam-Water-Mixing Valve

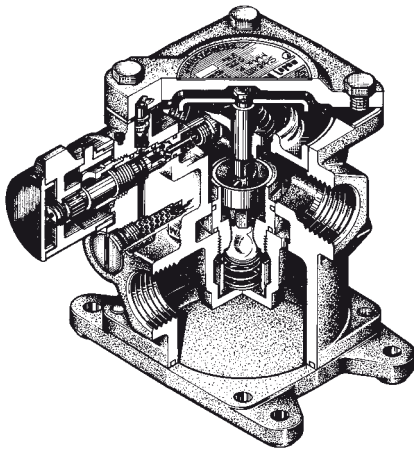

Dimensions

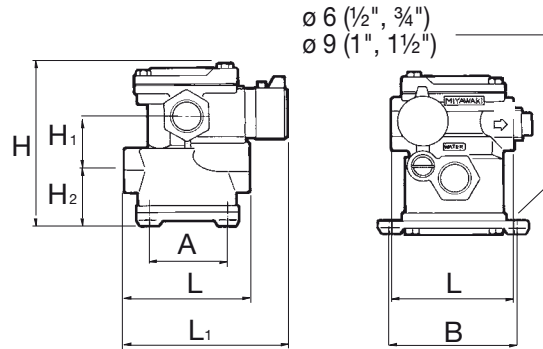

Connection	Size (in)	Max. Operating Pressure				Min. Operating Pressure				Max. Temperature	Max. Pressure Ratio	Max. Temperature	Dimensions mm (in)						Weight		
		Steam		Water		Steam		Water		Steam	steam : water water : steam	Hot Water	L	L ₁	H	H ₁	H ₂	A	B	kg	lb
		MPa	psig	MPa	psig	MPa	psig	MPa	psig	°C		°C	L	L ₁	H	H ₁	H ₂	A	B	kg	lb
Screwed Rc, NPT	1/2"											100 (3.9)	138 (5.4)	134 (5.3)	43 (1.7)	47 (1.9)	62 (2.4)	102 (4.0)	3,9	8.6	
	3/4"											140 (5.5)	179 (7.0)	168 (6.6)	57 (2.2)	51 (2.0)	86 (3.4)	147 (5.8)	8,6	18.9	
	1"	1.0	145	1.0	145	0.03	5	0.03	5	185	3 : 1	160 (6.3)	189 (7.4)	197 (7.8)	70 (2.8)	60 (2.4)	86 (3.4)	147 (5.8)	14,1	31.0	
	1 1/2"																				

Body Material: Brass C3771 (JIS)

Hot Water Capacity MX1N

Ratio Steam Pressure : Cold Water Pressure = 1 : 1, Cold Water Temperature 15°C

Size (in)	Pressure	Pressure	Hot Water Flow Amount (l/min)											
			40°C		50°C		60°C		70°C		80°C		90°C	
			Min.	Max.	Min.	Max.	Min.	Max.	Min.	Max.	Min.	Max.	Min.	Max.
1/2"	0,1	14.5	3	12	3	12	3	13	5	13	5	11	5	10
	0,2	29.0	3	20	3	21	3	21	5	20	5	17	10	14
	0,3	43.5	6	25	6	25	6	26	9	26	9	22	13	19
	0,4	58.0	6	29	6	29	6	29	12	30	12	28	17	24
	0,5	72.5	7	32	7	32	8	33	13	34	18	34	29	29
	0,6	87.0	7	35	7	36	16	36	17	37	27	37	34	34
	0,7	101.5	8	38	9	38	21	39	21	40	37	40	38	38
3/4"	0,1	14.5	5	22	5	23	5	20	8	17	8	14	9	12
	0,2	29.0	5	32	5	32	5	31	8	25	8	21	13	18
	0,3	43.5	8	39	8	39	8	40	10	34	10	28	25	25
	0,4	58.0	9	45	9	45	9	46	14	42	20	36	31	31
	0,5	72.5	11	50	11	51	11	52	15	51	23	43	37	37
	0,6	87.0	12	55	12	55	23	56	23	57	42	50	43	43
	0,7	101.5	14	59	15	60	44	61	45	62	56	56	49	49
1"	0,1	14.5	30	54	30	54	29	47	23	38	20	32	17	28
	0,2	29.0	38	76	39	77	48	70	37	57	31	49	27	42
	0,3	43.5	48	93	48	94	65	94	52	77	44	65	38	56
	0,4	58.0	54	107	55	109	66	111	67	97	57	82	49	71
	0,5	72.5	60	120	66	122	67	124	82	116	69	98	60	85
	0,6	87.0	66	131	67	133	68	135	97	136	82	115	71	100
	0,7	101.5	71	142	72	144	73	146	107	149	93	130	81	112
1 1/2"	0,1	14.5	91	140	83	116	64	90	53	74	45	63	39	54
	0,2	29.0	116	197	137	175	100	136	82	112	69	94	60	82
	0,3	43.5	136	242	170	235	136	183	112	149	94	126	82	110
	0,4	58.0	153	279	170	284	172	229	141	188	119	159	103	138
	0,5	72.5	171	312	173	317	210	276	172	226	146	191	126	166

Max. Temperature of hot water – Ratio Steam Pressure 1 : 1

1/2"	93°C	3/4"	93°C	1"	93°C	1 1/2"	93°C
------	------	------	------	----	------	--------	------

Please, look at our Website www.miyawaki.net (Products/Steam Water Mixing Valves) for more detailed flow charts containing hot water flow rates of the MX1N. If you require further technical details, please ask for our technical leaflet on Steam Water Mixing Valves.