

REC1

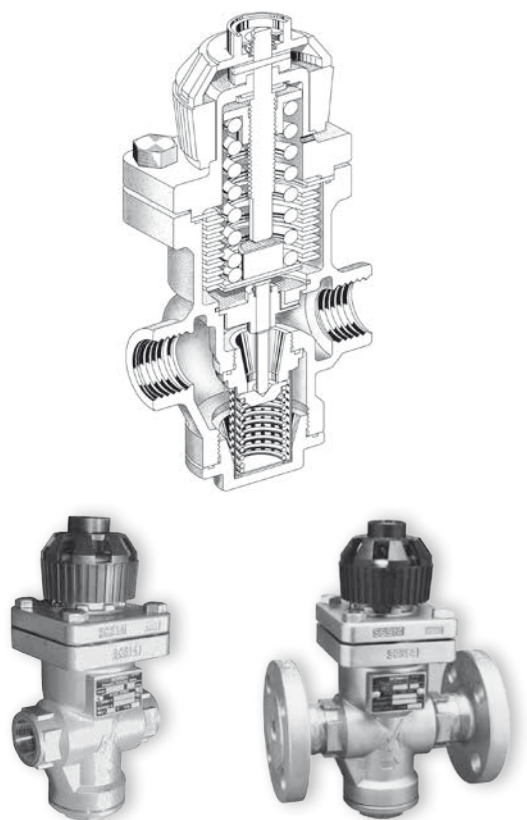

Minimum Differential Pressure:
 more than 10 % of Operating Pressure

Body Material:
 Stainless Steel SCS14

Capacity Chart REC1

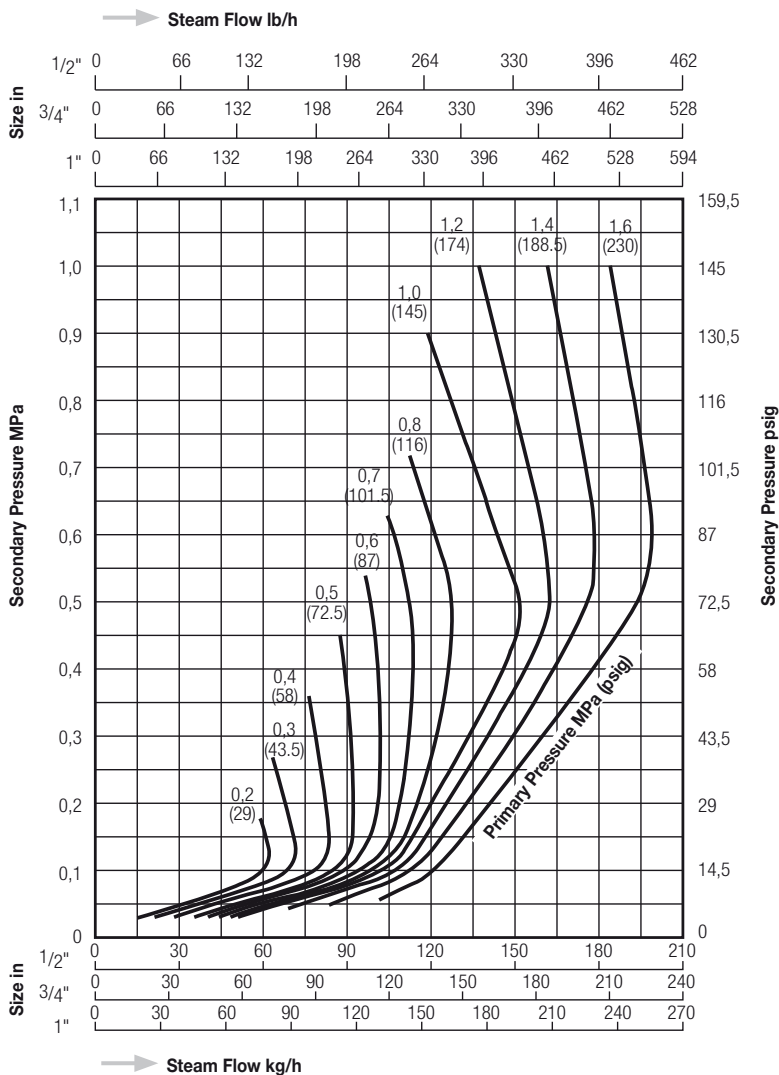

Dimensions

REC1 – Screwed

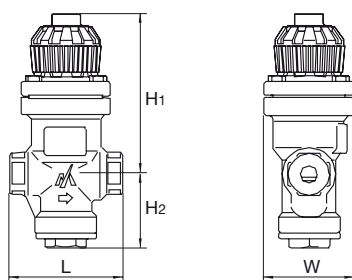

REC1 – Flanged

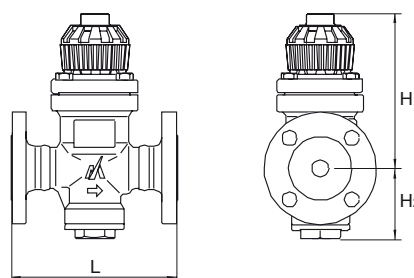

Model	Connections	Size (in)	Operating Pressure (Primary)		Secondary Pressure		Max. Red. Pressure Ratio	Max. Operating Temperature		Dimensions (mm)				Dimensions (in)				Weight	
			MPa	psig	MPa	psig		°C	°F	L	H1	H2	W	L	H1	H2	W	kg	lb
REC1-2	Screwed Rc, NPT, Rp	1/2" - 1"	0,2 - 1,6	29 - 230	0,02 - 0,2	2,9 - 29	30 : 1	220	428	96	138	63	78	3,8	5,4	2,5	3,1	2,9	6,4
REC1-6		1/2" - 1"	0,2 - 1,6	29 - 230	0,18 - 0,6	26 - 87	8,9 : 1											2,8	6,2
REC1-10		1/2" - 1"	0,6 - 1,6	87 - 230	0,54 - 1,0	78 - 145	3 : 1											2,8	6,2
REC1-2F	Flanged JIS, ASME, DIN	1/2"	0,2 - 1,6	29 - 230	0,02 - 0,2	2,9 - 29	30 : 1			150	138	63	78	5,9	5,4	2,5	3,1	4,5	9,9
		3/4"																5,1	11,2
		1"																5,9	13
REC1-6F		1/2"	0,2 - 1,6	29 - 230	0,18 - 0,6	26 - 87	8,9 : 1			150	138	63	78	5,9	5,4	2,5	3,1	4,5	9,9
		3/4"																5,1	11,2
		1"																5,9	13
REC1-10F	1/2"	0,6 - 1,6	87 - 230	0,54 - 1,0	78 - 145	3 : 1	150			138	63	78	5,9	5,4	2,5	3,1	4,5	9,9	
	3/4"																5,1	11,2	
	1"																5,9	13	