

The MIYAWAKI SCCV®-System: worldwide patented

MIYAWAKI's internationally patented Self Closing and Centering Valve SCCV®-System has proven its high reliability and effectiveness during more than two decades. Many thousands of steam traps equipped with the SCCV®-System have proven enormous advantages for our customers:

1. a substantially longer life compared with other steam traps
2. no partial or one-sided precipitate wear of valve and seat
3. greatly reduced wear of all internal parts due to the reduction of the closing forces required to maintain a seal
4. no steam loss for all Temperature Control Traps

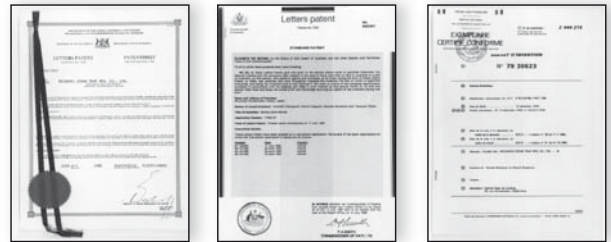

The MIYAWAKI SCCV®-System: variable adjusted to various types

Intensive research and development activities over many years have enabled MIYAWAKI to incorporate the SCCV®-System in various types of steam traps. Thus it became possible to adopt the SCCV®-System to a wide pressure range and to utilize the SCCV®-System not only for Bimetal Steam Traps, but also for Inverted Bucket and Float Type Steam Traps.

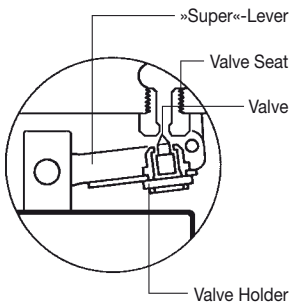
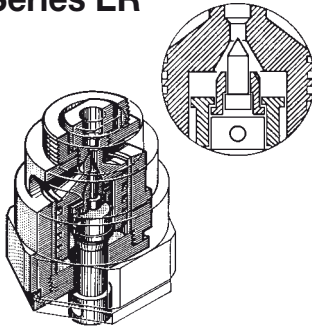
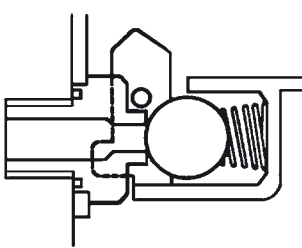
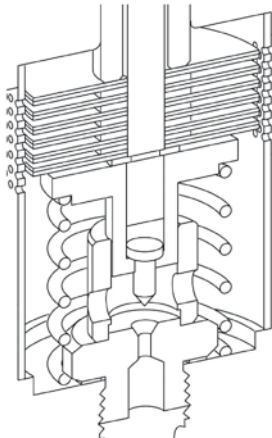
Inverted Bucket Steam Traps	Inverted Bucket Steam Traps
<p>Series ES</p>  <p>The Valve Holder is fixed to a specially developed »Super-Lever«. The Valve is »free floating« inside the Valve Holder. Thus the control space inside the Valve Holder decreases the force toward the seat caused by the movement of the bucket. The Valve will close softly and exactly in the center of the seat.</p>	<p>Series ER</p>  <p>The SCCV®-System is part of a »Double Valve Unit«, which is operating on the basis of the pressure difference inside the unit. The trap is thus characterized by extended life of the valve assembly and a greater condensate discharge per body size when compared to conventional Inverted Bucket steam traps.</p>
Ball Float Steam Trap	Temperature Control Steam Trap
<p>G11N, G12N</p>  <p>The Valve (Ball) lies inside a Valve Holder, which is directly connected through a lever with the float. By installing a spring inside the Valve Holder the movements of the float and the forces caused by it will not be directly transferred to the Valve. This will increase the service life of the sealing surfaces.</p>	<p>TB7</p>  <p>The Bimetal Unit including the Valve are guided inside the body. A spring reduces the force caused by the deflection of the bimetals which move the valve toward the seat. The guiding of the valve within the seat and the lift of the valve is designed in such a way that the Valve will close very smoothly in the center of the seat.</p>

Basic Principle

»Free Floating« of the Valve inside a Valve Holder – thereby precise closing of the valve in the center of the Seat.

Centering

A Spring and a Spring Plate within the Control Chamber absorbs and softens the movement of the valve into the seat (caused by the pressure and temperature of the steam).

Regulating

The upstream Valve/Seat design and the Valve lift (distance between the closed and open position of the valve) is designed in such a way that the valve will be closed by the flow of the condensate.

Soft Closing

No Steam Loss

TB51

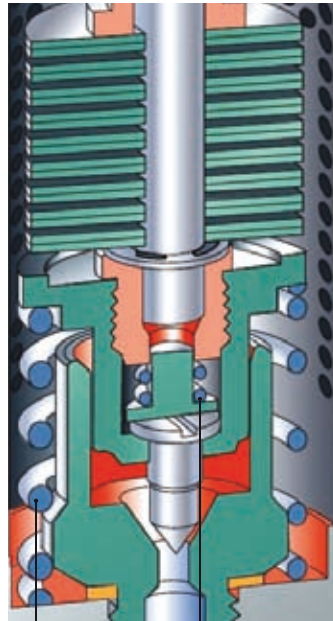

Spring No. 1 Spring No. 2

TB7

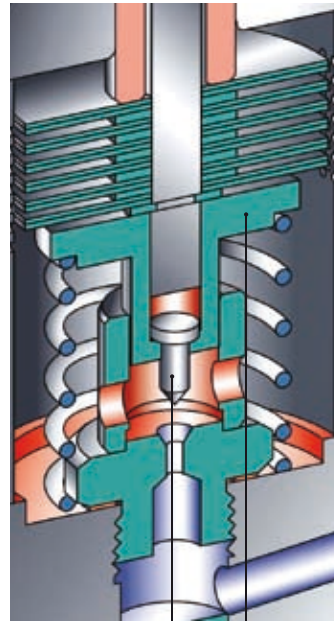

Valve Valve Holder

TB9

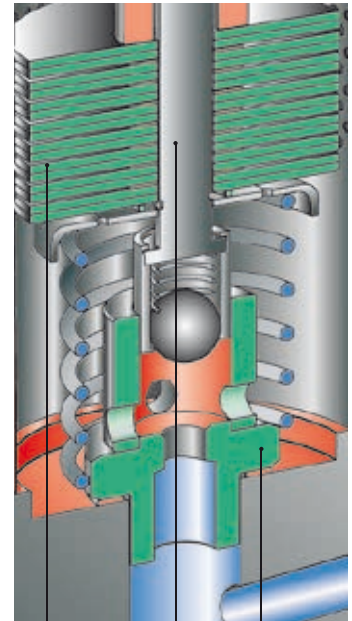

Bimetal Seat Valve Stem

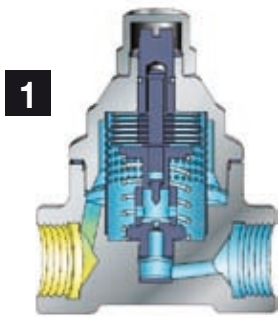

On start-up, the bimetal discs are all flat and the valve shaft is up with the valve fully open. Virtually all cold condensate and air are discharged.

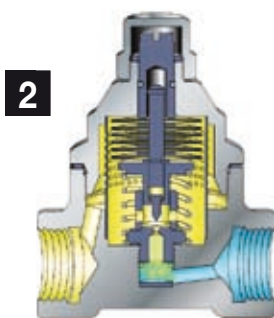

As the temperature of the condensate increases, the bimetal discs begin to curve gradually and force the valve shaft and the valve holder to move down.

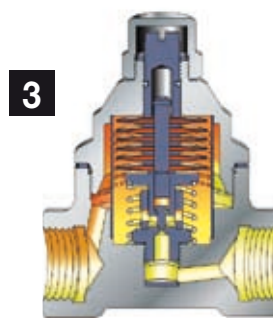

When condensate with higher temperature (near to set temperature) flows in, the bimetal discs are curved even more and, at the same time, the valve shaft moves down and the valve holder closes the holes in the guide partially.

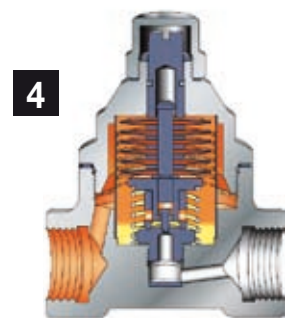

In case of very low condensate flow, the holes in the guide are closed completely by the valve holder and the valve will close precisely in the center of the seat. Normally, the trap is filled with hot condensate and the operation will rest in the state shown in figure 3. Condensate will be discharged continuously.

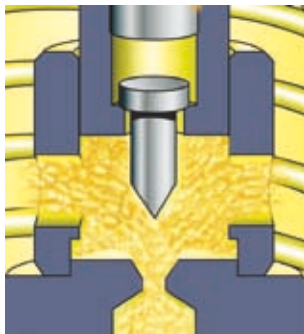

Most of the condensate is still discharged quickly, since the valve and the holes in the fixed guide on the valve seat are still fully open.

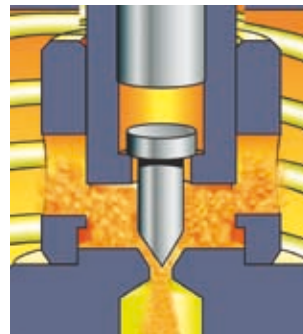

The amount of condensate being discharged is reduced quickly. This prolongs the time that the hot condensate stays near the bimetal discs and the heat of the condensate is transferred to the bimetal much more effectively.