

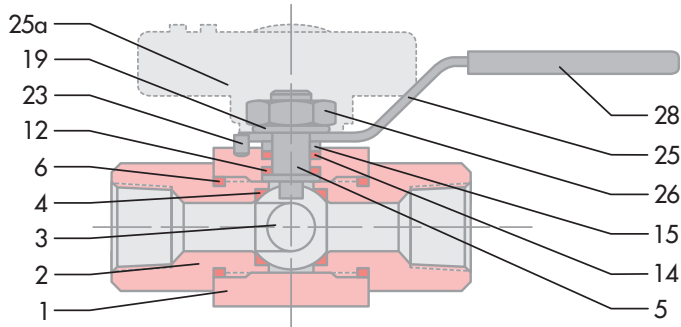

## INSTALLATION – MAINTENANCE MANUAL 3HP SERIES BALL VALVES



### Installation Guide

It is important that the middle port on the valve **IS NOT MOVED** otherwise damage will occur to the seats.

1. Before installing the valves, firstly make sure that the pipework has been cleaned and there is no trace of debris or loose pieces of metal in the pipe or system.
2. Prepare the threaded pipe for connection to the valve using either a thread sealant or PTFE tape, ensuring that there is no surplus tape over the open pipe and that may become dislodge and be carried through the pipework system.
3. Taper Threads: Carefully insert the pipe threaded end into the valve and tighten gently until resistance is felt. The pressure tight joint can then be made by tightening a further 1/2 to 1 turn as a guide. This will help prevent over-tightening and having the risk of damaged threads and resultant scrapping of components as a result of poor connection.
4. Parallel Threads: These threads are designed for face sealing and not bottom face sealing. Using a suitable bonded washer, insert the threaded pipe into the valve using a suitable lubricant or sealant if required and tighten until resistance is felt. The pipe thread can then be sealed with a further 1/4 turn to ensure that the face of the thread seals with the washer where used. Threads can be sealed using a pipe sealant but care must be taken so as not to 'bottom' the thread and hence cause damage to the lead thread on the male end which may damage all the threads on removal.
5. When purging the system prior to use, make sure that the valve is in the fully open position so that any loose particles that may remain in the system will not mark the ball or be trapped between the ball and the seats

Item	Name	Material	Qty.
1	Body	Stainless Steel 316	1
2	End Connector	Stainless Steel 316	2
3	Ball	Stainless Steel 316	1
4	Seat*	PVDF	2
5	Stem	Stainless Steel 316	1
6	Body Seal*	RPTFE	2
12	Thrust Washer*	RPTFE	1
14	Stem Packing*	RPTFE	1
15	Packing Gland	Stainless Steel	1
19	Lock Washer	Stainless Steel	2
23	Stop Pin	Stainless Steel	1
25	Lever Handle	Stainless Steel	1
25a	Pointer Handle	Mazak 3	1
26	Lock Nut	Stainless Steel	1
28	Handle Sleeve	Vinyl	1

as this will result in shorter life or leaking of the valve.

6. Finally, the gland seal is designed to be adjustable and, should the seals settle between manufacturing and installation, then it is suggested that 1/8 turn clockwise will ensure no leakage or stop any small weepage that may occur. This is not a design fault by and adjustable item.

### Operation Guide

This valve is designed to operate with pressure being applied to the **CENTER PORT ONLY**. It is not designed to isolate pressure for either side port.

Side entry style, the handle rotates 90° from open 6 to 3, to open on the opposite side outlet 6 to 9.

### Dismantling Instructions:

1. Remove the valve from the pipeline using a spanner on the end connector for each side of the pipe.
2. Clean the valve of any residual material.
3. Take out each end connector, holding the spare body whilst unscrewing each end.
4. Ensure that the handle is in the closed position and push out the ball and seats in either direction.
5. Remove the handle retaining nut and take both the handle and the nut off.



6. Push the stem out through the body bore to access both stem seals and remove them.
7. Inspect the ball for any signs of damage or wear, if it has either, consult the factory for a replacement.

#### **Assembly Instructions:**

1. Ensure that you have the correct repair kit for the pressure rating of the valve.
2. Ensure that all parts are cleaned before assembly.
3. Place the stem seal (5) onto the stem (4) being careful not to damage it.
4. Insert the stem through the stem hole from inside the valve bore and push firmly into place. Put the top seal (7) onto the stem and fit the spacer (14) and the lever handle (10) in that order, then apply the nut (12) carefully so as not to cross thread it. This can be tightened to hold the parts in place.

5. Place the valve seat (6) into the bore on one side, make sure that the flat face is pointing away from the center of the valve.
6. Repeat (5) for the opposite side after inserting the ball ensuring that the stem tongue is fitted into the slot on the top of the ball. Then turn the handle 90 degrees to ensure engagement and to hold the ball in place.
7. Place the new body seal ring (8) onto each end connector (2) and insert into the valve body and with the ball in the closed position, tighten up the end connectors to a torque of 220Nm on both sides.
8. Finally adjust the handle nut so as to stop any leaks but without overtightening so as to cause excessive torque for turning the valve.

#### **Notes:**

Valves fitted with a pointer handle **DO NOT** have the spacer (14) fitted and this part of the step can be ignored in the assembly instructions.