

SERIES E Inverted Bucket Trap – Low Pressure

ES

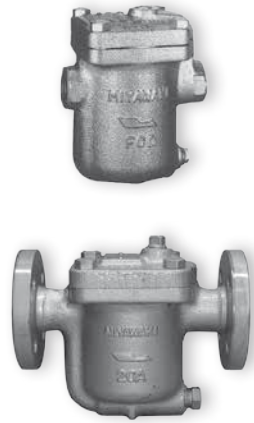

Dimensions

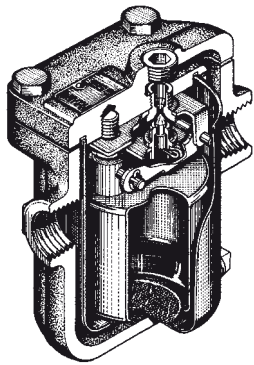
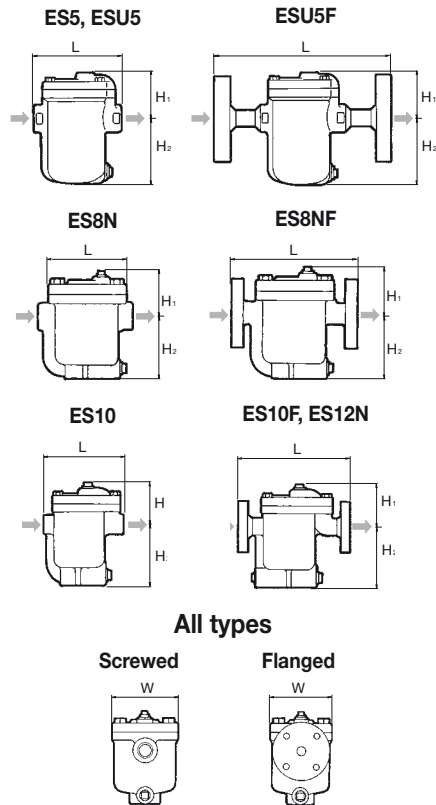

Available options

Depending on the Maximum Operating Pressure the following types are available:

Model	Max. Operating Pressure	
	MPa	psig
ES5 - 3	0,3	43
ES5 - 7	0,7	100
ES5 - 11	1,1	160
ES5 - 16	1,6	230
ESU5 - 3	0,3	43
ESU5 - 7	0,7	100
ESU5 - 11	1,1	160
ESU5 - 16	1,6	230
ESU5 - 21	2,1	300
ES8N - 5	0,5	73
ES8N - 8	0,8	116
ES8N - 16	1,6	230
ES10 - 8	0,8	116
ES10 - 12	1,2	174
ES10 - 16	1,6	230

Capacity Charts ES

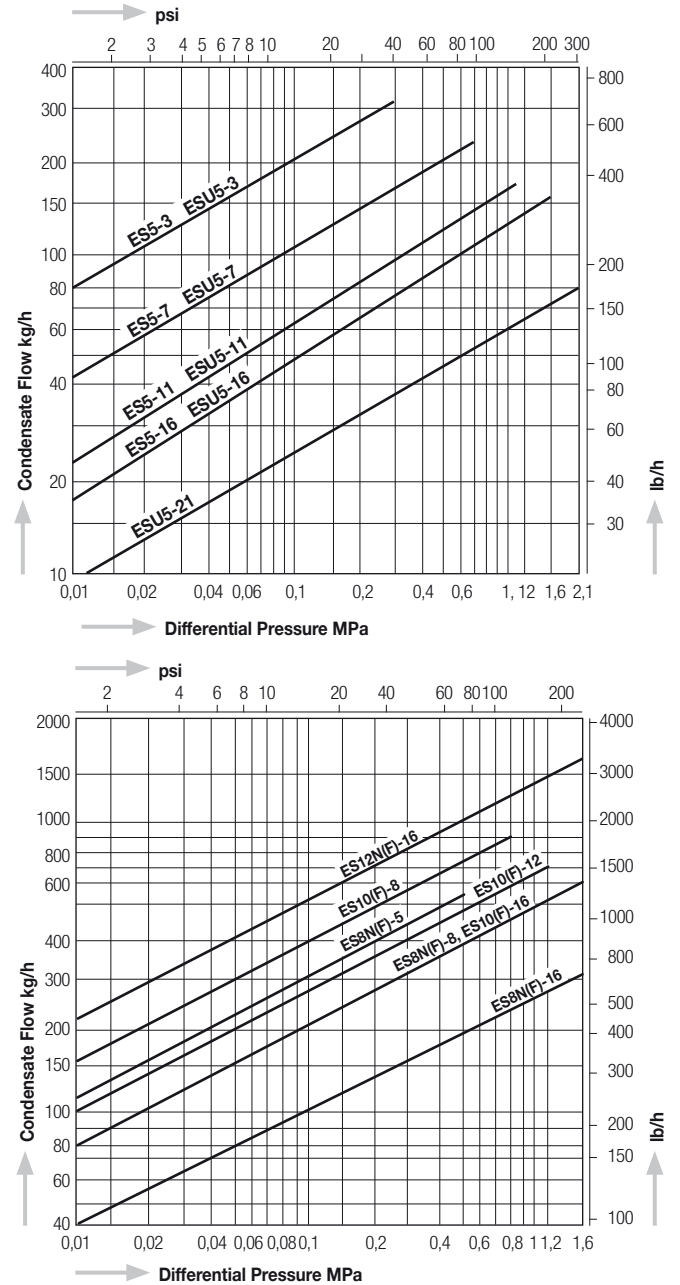

Model	Connections	Size (in)	Max. Operating Pressure		Max. Operating Temperature		Dimensions (mm)				Dimensions (in)				Body Material	Weight	
			MPa	psig	°C	°F	L	H ₁	H ₂	W	L	H ₁	H ₂	W		kg	lb
ES5	Screwed Rc, NPT	1/2"	1,6	230	350	662	103	59	67		4.1	2.3	2.6	3.0	Ductile Cast Iron FCD450	1,9	4,2
		105					57	69	75	4.1	2.2	2.7	1,9			4,2	
		109								4.3			2,0			4,4	
ESU5	Screwed Rc, NPT	1/2"	2,1	305	350	662	103				4.1			3.0	Stainless Steel SCS13A	1,9	4,2
		105					57	69	75	4.1	2.2	2.7	2,0			4,4	
		109								4.3			2,1			4,6	
ESU5F	Flanged JIS, ASME, DIN	1/2"	2,1	305	350	662	175				6.9			3.0	Stainless Steel SCS13A	3,5	7,7
		195					57	69	75	7.7	2.2	2.7	3,7			8,2	
		215								8.5			4,1			9,0	
ES8N	Screwed Rc, NPT	1/2"	1,6	230	350	662	130	73	90	100	5.1	2.9	3.5	3.9	Ductile Cast Iron FCD450	3,7	8,2
		135								5.3			3,9			8,6	
		175					73	90	100	6.9	2.9	3.5	5,3			11,7	
ES8NF	Flanged JIS, ASME, DIN	1/2"	1,6	230	350	662	195				7.7			3.9	Ductile Cast Iron FCD450	5,7	12,5
		215					68	95	100	8.5	2.7	3.7	6,8			15,0	
ES10	Screwed Rc, NPT	3/4" - 1 1/2"	1,6	230	220	428	190	102	134	120	7.5	4.0	5.3	4.7	Cast Iron FC250	9,3	20,5
		254								10.0			12,7			28,0	
		260					102	134	120	10.2	4.0	5.3	14,2			31,2	
ES10F	Flanged JIS, ASME, DIN	1/2" - 1"	1,6	230	220	428	270	140	140	120	10.6	5.5	5.5	4.7	Cast Iron FC250	13,5	29,7
		280					150	130	120	11.0	5.9	5.1	15,1			33,2	
ES12N	Flanged JIS, ASME, DIN	1 1/4" - 2"	1,6	230													

ESH

Capacity Chart ESH

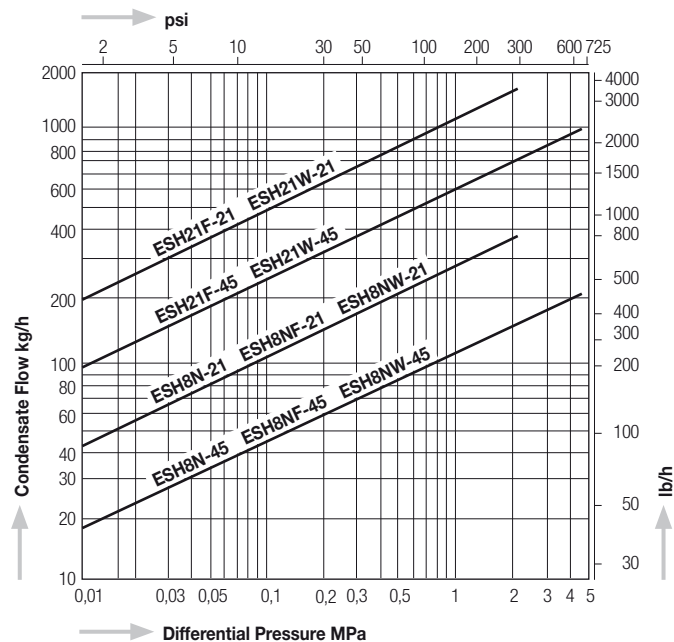
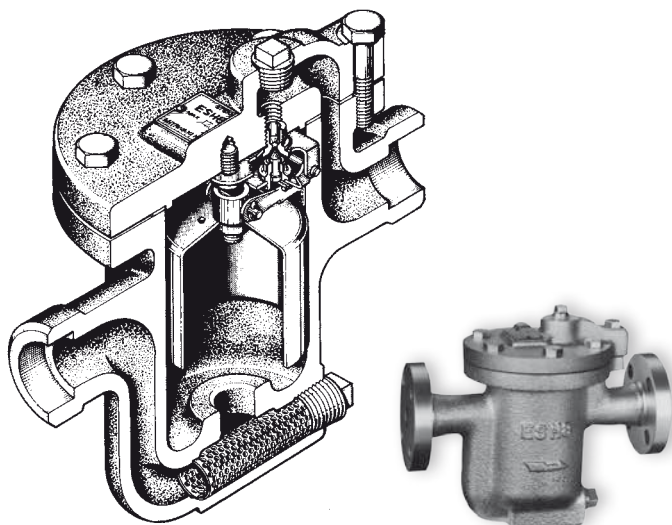

Dimensions

ESH8N, ESH8NW

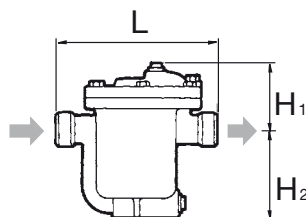

ESH8NF

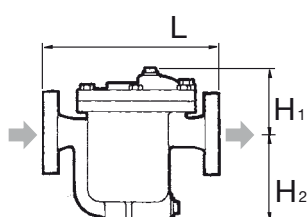

ESH21W

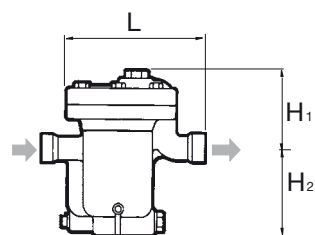

ESH21F

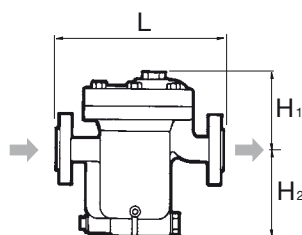

All types

Screwed, Socket Weld

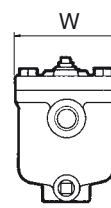

Flanged

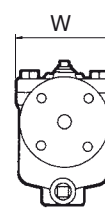

Model	Connections	Size (in)	Max. Operating Pressure		Max. Operating Temperature		Dimensions (mm)				Dimensions (in)				Body Material	Weight	
			MPa	psig	°C	°F	L	H ₁	H ₂	W	L	H ₁	H ₂	W		kg	lb
ESH8N - 21 45	Screwed Rc, NPT	½" - 1"	2,1	305	400	752	½" - ¾" = 220 1" = 224	114	111	146	½" - ¾" = 8.7 1" = 8.8	4.5	4.4	5.7	Cast Steel SCPH2	11,0	24.2
			4,4	640													
ESH8NF - 21 45	Flanged JIS, ASME, DIN	½" - 1"	2,1	305			250	114	111	146	9.8	4.5	4.4	5.7		½", ¾" = 12,3 1" = 13,1	27.1 28.8
			4,4	640													
ESH8NW - 21 45	Socket Weld ASME, DIN	½" - 1"	2,1	305			220	114	111	146	8.7	4.5	4.4	5.7		11,0	24.2
			4,4	640													
ESH21F - 21 45	Flanged JIS, ASME, DIN	½" - 1"	2,1	305			350	145	160	205	13.8	5.7	6.3	8.1		31,0	68.2
			4,4	640													
ESH21W - 21 45	Socket Weld ASME, DIN	½" - 1"	2,1	305			300	145	160	205	11.8	5.7	6.3	8.1		28,0	61.6
			4,4	640													