

**INSTALLATION, OPERATION and  
MAINTENANCE MANUAL**

**“BELL MIGHTY  
Inverted Bucket Steam Trap  
MODEL: ESH21 SERIES**



**MIYAWAKI INC.**

Osaka, Japan

## SAFETY INSTRUCTION

Prior to using ESH series, read this manual thoroughly to understand the correct handling and operating procedure.

The manual should be used by experienced personnel as a guide to the installation and maintenance of the Steam Traps.

We ask you to contact MIYAWAKI or its local representative if further information is required.

### 1. Dimensions and Technical Specification

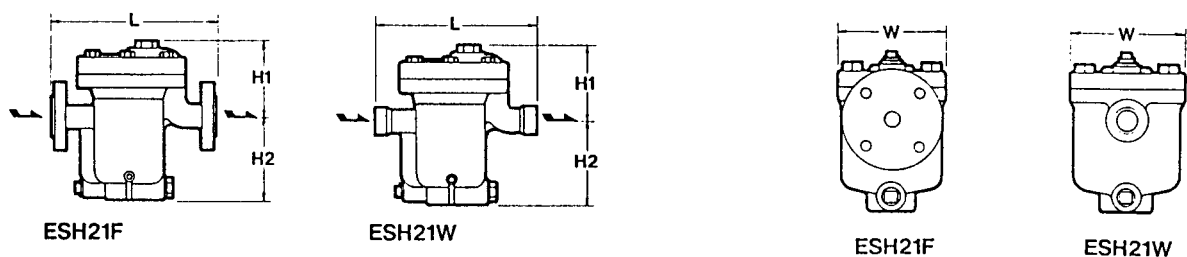

Model No.	Conne- ction	Size mm (inch)	Maximum Operating Pressure barg (psig)	Maximum Operating Temper. °C (°F)	Body Material	Dimensions mm (inch)				Weight kg (lb)	
						L	H1	H2	W		
ESH21F-21	Flanged	15(1/2)	21 (305)	425 (797)	Cast Carbon Steel  SCPH 2	350 (13.8)	145 (5.7)	160 (6.3)	205 (8.1)	31 (68)	
ESH21F-45		20(3/4)									44 (640)
		25(1)									
ESH21W-21	Socket	15(1/2)	21 (305)								
		20(3/4)									
		25(1)									
ESH21W-45	Weld	15(1/2)	44 (640)	300 (11.8)					28 (62)		
		20(3/4)									
		25(1)									

## 2. Installation

<b>CAUTION</b>	Before installing the trap, always blow down the piping that leads to the trap's inlet.
----------------	---

<b>CAUTION</b>	The Bell Mighty inverted bucket steam trap Model ESH can only be installed horizontally.
----------------	--

- A. Install the trap according to the direction of the arrow on the body.
- B. Install the trap at the lowest point of the steam using equipment to be drained.
- C. Install the trap so that the condensate will flow naturally into the trap.
- D. When recovering the condensate, the outlet branch line should be piped from the steam trap as shown in drawing A.

It is recommended to install a check valve on the downstream side of the trap.

- E. If the trap is installed higher than the steam using equipment, use a lift fitting as shown in drawing B for better performance.
- F. If the trap is used for draining a cylinder dryer, please, install it lower than the lowest point of the cylinder and minimize the horizontal piping.  
Do not insulate the piping.

G. The trap should be installed for easy maintenance.

H. Upon start up inspect the following:

1. Eventual leakage from the sealing of the Body (1) and the Cover (2). If the trap is leaking retighten the cover bolts (20) evenly crosswise.
2. Eventual leakage from the Plugs (3) or (4). If the trap is leaking retighten the plugs.

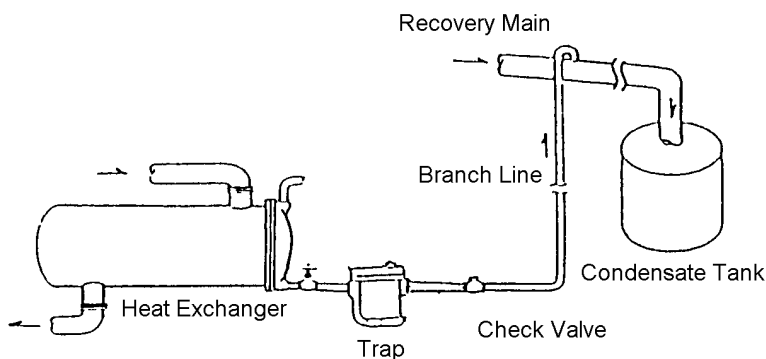

Drawing A

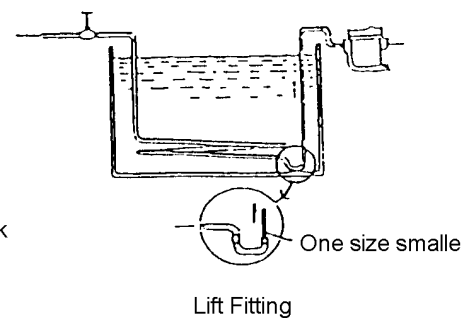

Drawing B

### 3. Trouble-shooting

The steam trap should be checked for proper operation at least once a year.

The inverted bucket steam trap is operating intermittently, i.e. it will discharge the condensate and close at certain cycles.

Improper operations will be:

- No discharge
- Continuous discharge of condensate or steam.

Problem	Reason
The trap is not discharging. The trap is cold.	A. The inlet valve is closed. B. The operating pressure is too high. Check the operating conditions of the trap. If necessary reduce the inlet pressure or change the valve (No. 6) and the valve seat (No. 7) according to the higher operating pressure. C. The strainer is plugged. Remove the Body Plug (No.3) and clean the strainer. D. The air vent (hole in the bucket) is plugged. E. The valve seat is plugged.
The trap is not discharging. The trap is hot.	A. No Condensate is flowing to the trap. <ul style="list-style-type: none"> <li>- The by-pass valve or flange upstream are leaking.</li> <li>- In case of cylinder dryers the syphon tube is damaged or broken.</li> <li>- A vacuum had been created at the upstream piping.</li> </ul> Install a vacuum breaker upstream.
The Trap is discharging continuously condensate.	A. The capacity of the trap is too low.
The trap is blowing through steam.	A. Loss of prime The ESH model has a self-priming effect. If a normal amount of condensate is flowing into the trap, it will self-prime. B. Scale is lodged between the valve and the valve seat. C. The valve or the valve seat are damaged.

### 4. Maintenance, Disassembling and Assembling

<b>WARNING</b>	Before disassembling a steam trap be sure to close the valves in both supply and discharge lines, reduce the pressure inside the trap to atmospheric pressure, and allow the trap to cool before opening it.
----------------	--

For cleaning purposes or for changing parts perform the following steps:

- A. Remove the Body Plug (3), take out the Screen (17), check and clean it.
- B. Remove the Cover Bolts (20). Take off the Cover (2) together with all internal parts ( Valve Seat (5), Valve (6), Valve Holder (7), Pin (8), Bucket (9), Eye Bolt (10), Eye Bolt Pin (12), Lever (13), Bracket (14), Pin (15), Set Bolt (16) as shown in drawing C).

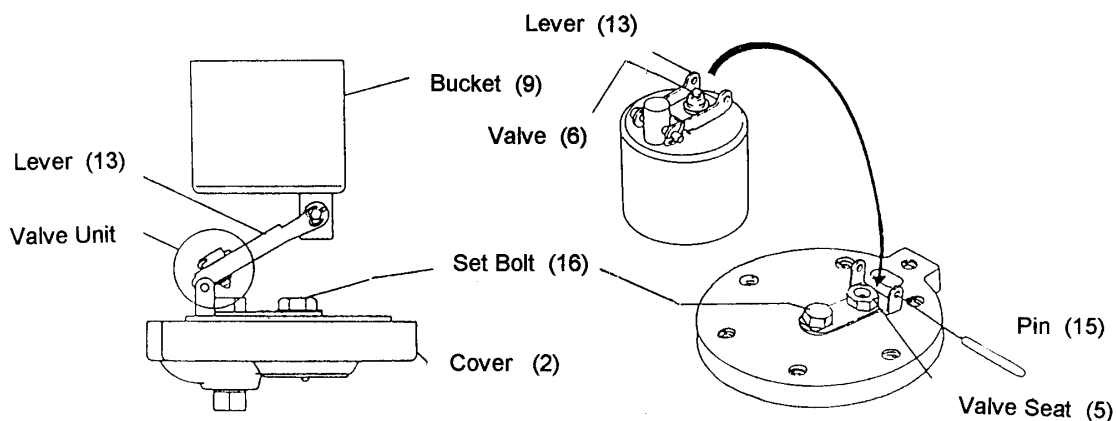

Drawing C

- C. Take off the Pin (15), unscrew the Set Bolt (16) and the Valve Seat (5) with a wrench.
- D. Take off the Pin (8). The Valve (6) and the Valve Holder (7) can be removed from the Lever (13).
- E. Take off the split pin and Eye Bolt Pin (12), unscrew the U-Nut (27) with a box wrench. You can take off the bucket (9) .
- F. Clean and inspect all parts. Replace any that are worn or damaged. Assemble in the opposite way as disassembling.

Especially thoroughly check the Valve (6), the Valve Seat (5) and the Valve Holder (7). When there will be the necessity to replace the Valve (6) and/or the Valve Seat (5) always replace both together as they are lapped together in the factory.

<b>CAUTION</b>	When reassembling always replace the Cover Gasket (21) by a new one.
----------------	--

<b>CAUTION</b>	Tighten the Cover Bolts (20) evenly crosswise.
----------------	--

**Wrench Sizes and Torques**

Parts Number	Parts Name	Wrench Size	Torque
20	Cover Bolt	24 mm	2,500 kgf·cm
16	Set Bolt	13 mm	210 kgf·cm
5	Valve Seat	23 mm	600 kgf·cm

## 5. Details and Spare Parts List

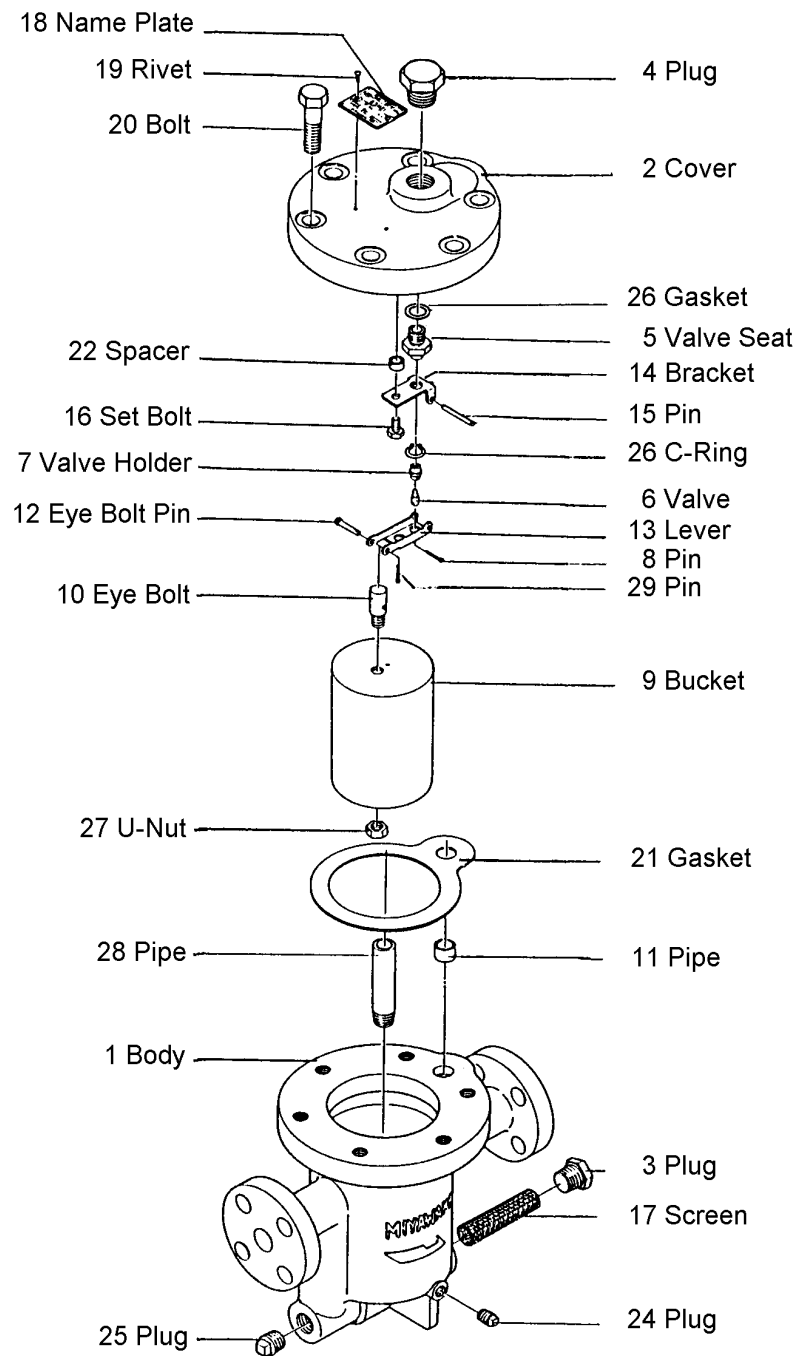

### SPARE PARTS LIST

No.	Parts / Unit Name
5-8, 10, 12-16, 22, 23, 26, 27, 29	Valve & Valve Seat Unit
9	Bucket
21	Cover Gasket
17	Screen