

G11N, G12N

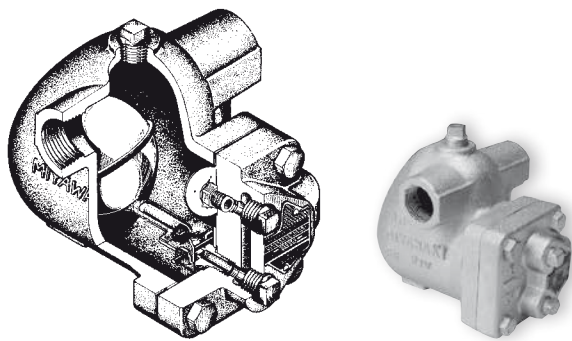

G15N

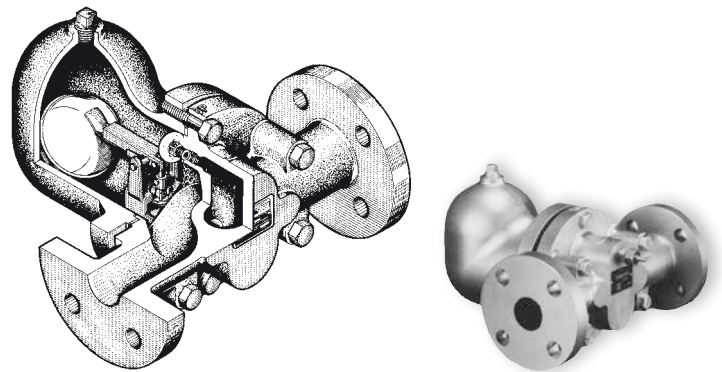

Capacity Chart G11N, G12N

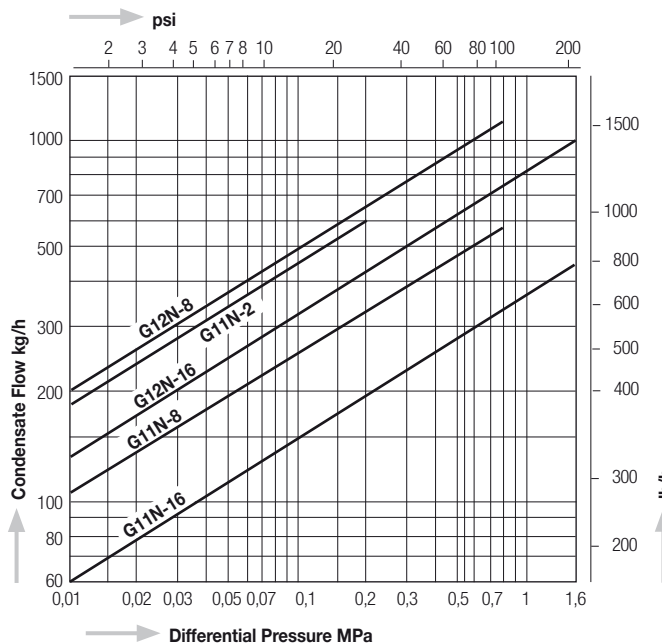

Capacity Chart G15N

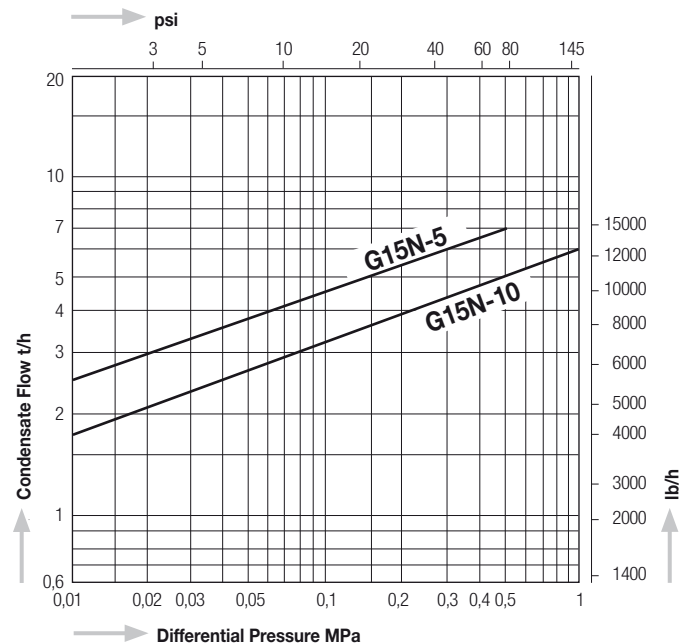

Dimensions G11N, G12N

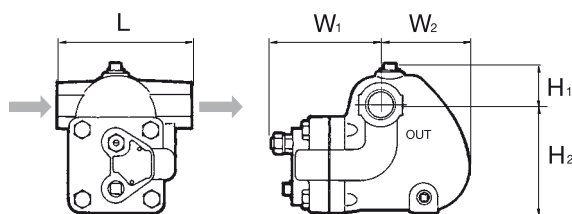

G15N

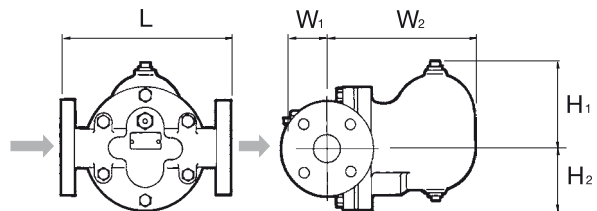

Model	Connections	Size (in)	Max. Operating Pressure		Max. Operating Temperature		Dimensions (mm)					Dimensions (in)					Body Material	Weight			
			MPa	psig	°C	°F	L	H ₁	H ₂	W ₁	W ₂	L	H ₁	H ₂	W ₁	W ₂		kg	lb		
G11N - 2 8 16	Screwed Rc, NPT	½", ¾"	0,2	29	220	428	120	37	92	97	60	4.7	1.5	3.6	3.8	2.4	Cast Iron FC250	3,9	8.6		
			0,8	116																	
			1,6	230																	
G12N - 8 16	Screwed Rc, NPT	¾", 1"	0,8	116	220	428	140	47	113	102	92	5.5	1.9	4.4	4.0	3.6				5,9	13.0
			1,6	230																	
G15N - 5 10	Flanged ASME, DIN	1¼" - 2"	0,5	73	220	428	300	130	90	30	230	11.8	5.1	3.5	1.2	9.1				20,0	44.0
			1,0	145																	