

GC1

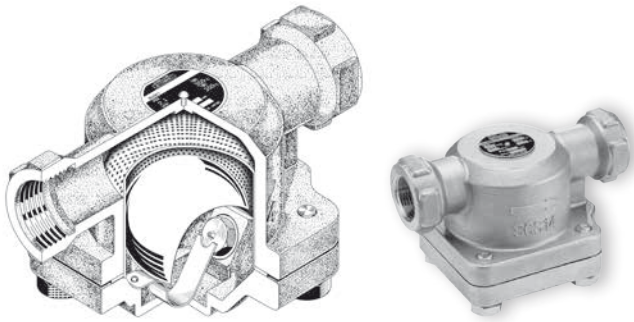

Horizontal installation

GC1V

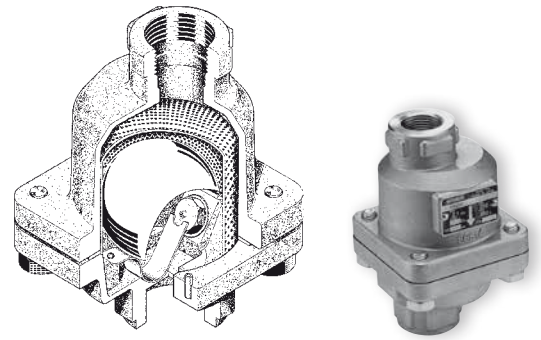

Vertical installation

Dimensions

GC1

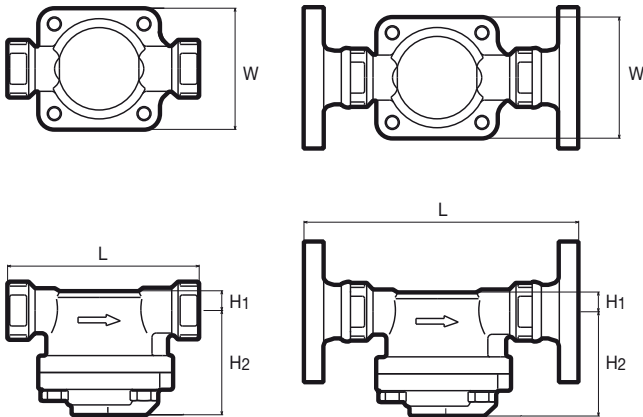

GC1V

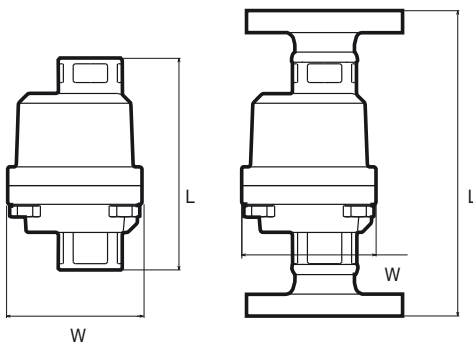

Capacity Chart GC1 / GC1V

Standard
On request

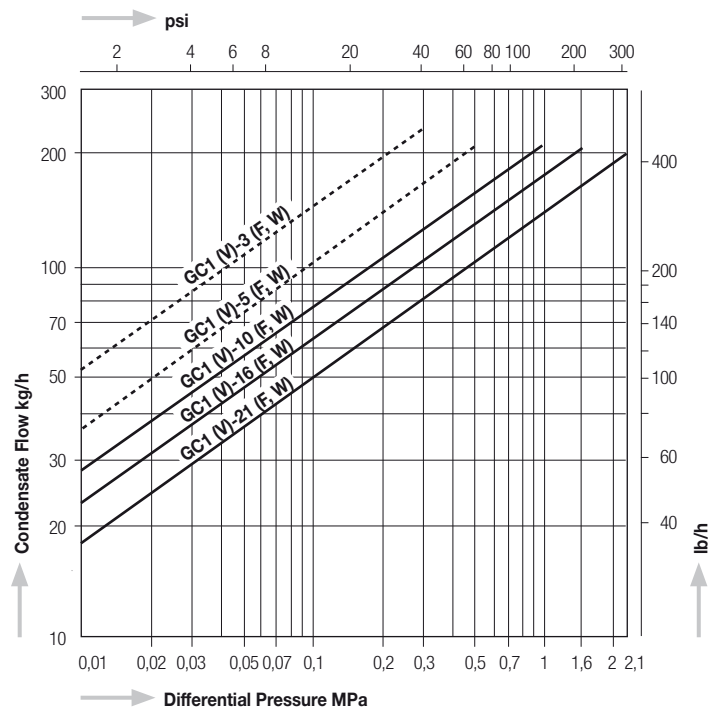

Table 1: Available pressure ranges GC1/GC1V

Model	Max. Operating Pressure		
	MPa	psig	
GC1 / GC1V - 21	2,1	305	Standard
GC1 / GC1V - 16	1,6	230	
GC1 / GC1V - 10	1,0	145	
GC1 / GC1V - 5	0,5	72.5	On request
GC1 / GC1V - 3	0,3	43.5	

Model	Connections	Size (in)	Operating Pressure Range		Max. Operating Temperature		Dimensions (mm)				Dimensions (in)				Body Material	Weight	
			MPa	psig	°C	°F	L	H1	H2	W	L	H1	H2	W		kg	lb
GC1 (GC1V)	Screwed Rc, NPT	1/2"	0,01 - 2,1	1.5 - 305	350	662	127	15	75	86	5.0	0.6	3.0	3.4	Stainless Steel SCS13A	1,8	4.0
		3/4"					136				5.4					1,9	4.2
		1"					140				5.5					2,0	4.4
GC1-W (GC1V-W)	Socket Weld JIS, ASME, DIN	1/2"	0,01 - 2,1	1.5 - 305	350	662	127	15	75	86	5.0	0.6	3.0	3.4		1,8	4.0
		3/4"					136				5.4					1,9	4.2
		1"					140				5.5					2,0	4.4
GC1-F (GC1V-F)	Flanged JIS, ASME, DIN	1/2"	0,01 - 2,1	1.5 - 305	350	662	175	15	75	86	6.9	0.6	3.0	3.4	3,3	7.3	
		3/4"					195				7.7				4,5	9.9	
		1"					215				8.5				5,3	11.7	