

# GH40

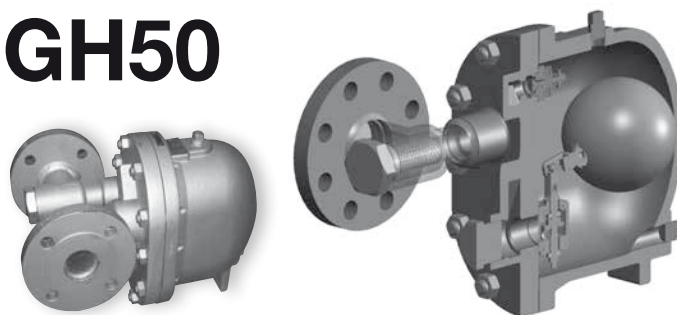

# GH50



Capacity Chart GH40

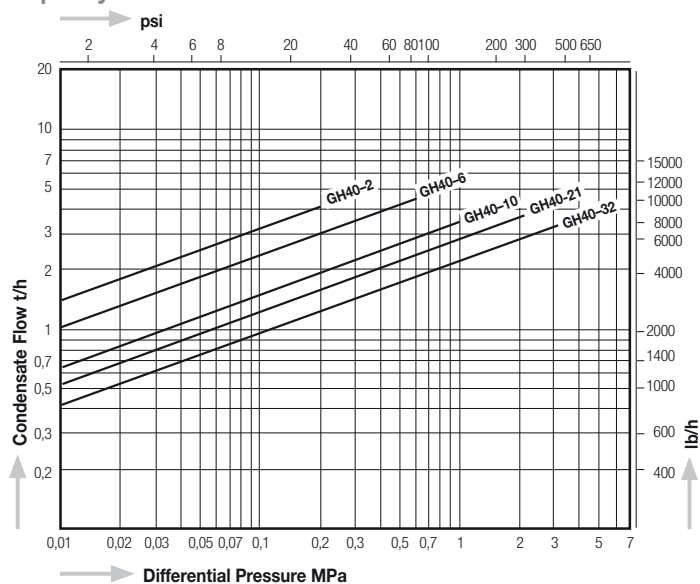

Capacity Chart GH50

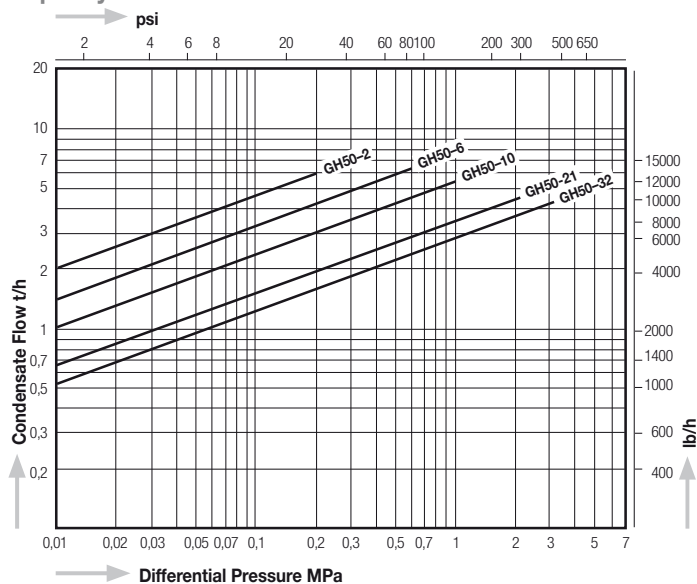

Dimensions

GH40-F

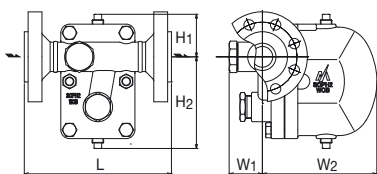

GH50-F

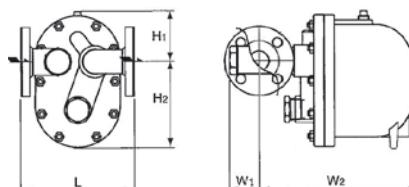

GH40-W

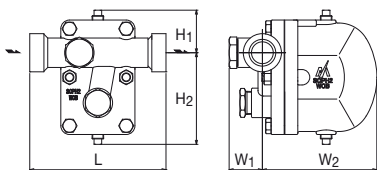

GH50-W

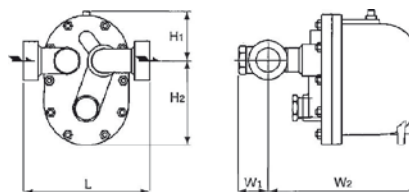

| Model    | Connections                   | Size (in) | Max. Operating Pressure, PMO |          | Max. Operating Temperature, TMO |     | Dimensions (mm) |                |                |                |                | Dimensions (in) |                |                |                |                | Body Material       | Weight |      |
|----------|-------------------------------|-----------|------------------------------|----------|---------------------------------|-----|-----------------|----------------|----------------|----------------|----------------|-----------------|----------------|----------------|----------------|----------------|---------------------|--------|------|
|          |                               |           | MPa                          | psig     | °C                              | °F  | L               | H <sub>1</sub> | H <sub>2</sub> | W <sub>1</sub> | W <sub>2</sub> | L               | H <sub>1</sub> | H <sub>2</sub> | W <sub>1</sub> | W <sub>2</sub> |                     | kg     | lb   |
| GH40 - F | Flanged<br>JIS, ASME, DIN     | 1½", 2"   | 0,2 – 3,2                    | 29 – 464 | 400                             | 752 | 230             | 80             | 170            | 60             | 210            | 9.1             | 3.15           | 6.7            | 2.4            | 8.3            | Cast Steel<br>SCPH2 | 24     | 53   |
| GH40 - W | Socket Weld<br>JIS, ASME, DIN | 1½"       |                              |          |                                 |     | 250             | 80             | 170            | 60             | 210            | 9.8             | 3.15           | 6.7            | 2.4            | 8.3            |                     | 19     | 41.9 |
|          |                               | 2"        |                              |          |                                 |     | 260             | 10.2           | 6.7            | 2.4            | 8.3            | 37              | 81.4           |                |                |                |                     |        |      |
| GH50 - F | Flanged<br>JIS, ASME, DIN     | 1½", 2"   |                              |          |                                 |     | 230             | 107            | 173            | 60             | 330            | 9.1             | 4.2            | 6.8            | 2.4            | 13.0           |                     | 37     | 81.4 |
| GH50 - W | Socket Weld<br>JIS, ASME, DIN | 1½"       |                              |          |                                 |     | 250             | 107            | 173            | 60             | 330            | 9.8             | 4.2            | 6.8            | 2.4            | 13.0           |                     | 32     | 70.4 |
|          |                               | 2"        |                              |          |                                 |     | 260             | 10.2           | 6.8            | 2.4            | 13.0           |                 |                |                |                |                |                     |        |      |

| Available pressure ranges | Max. Operating Pressure (PMO)            |    |  |    |  |     |  |     |  |     |      |  |
|---------------------------|--|----|--|----|--|-----|--|-----|--|-----|------|--|
|                           | MPa                                      |    | psig                                     |    | MPa  |     | psig   |     | MPa  |     | psig |  |
|                           | 0,2                                      | 29 | 0,6                                      | 87 | 1,0  | 145 | 2,1  | 305 | 3,2  | 464 |      |  |
| Models                    | GH40-2F<br>GH40-2W<br>GH50-2F<br>GH50-2W |    | GH40-6F<br>GH40-6W<br>GH50-6F<br>GH50-6W |    | GH40-10F<br>GH40-10W<br>GH50-10F<br>GH50-10W |     | GH40-21F<br>GH40-21W<br>GH50-21F<br>GH50-21W |     | GH40-32F<br>GH40-32W<br>GH50-32F<br>GH50-32W |     |      |  |

Depending on the flange standard the dimensions and the weight may differ.