

# GH60

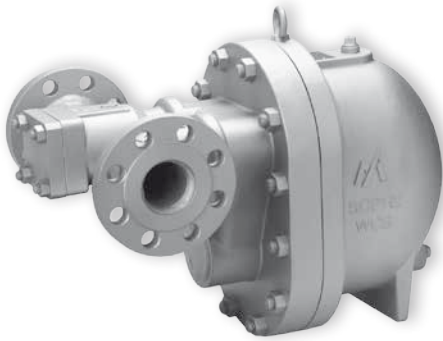

# GH70

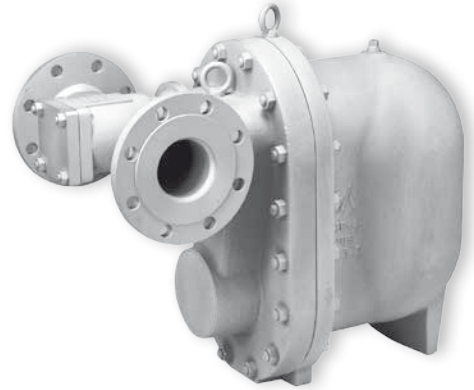

Capacity Chart GH60

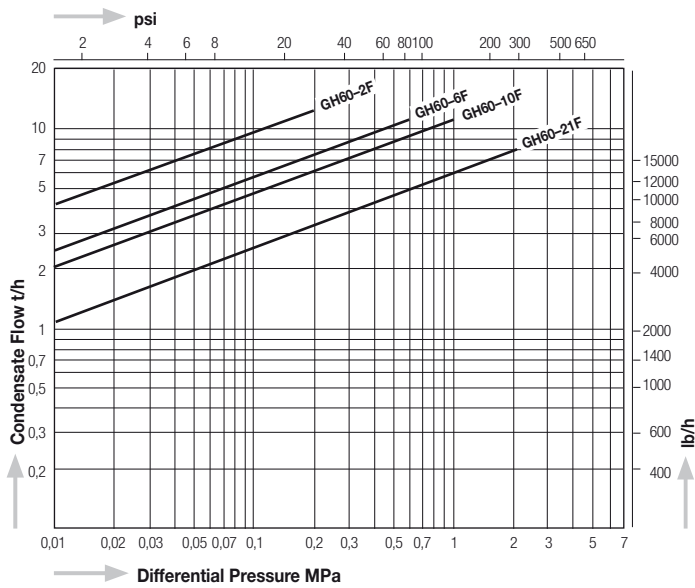

Capacity Chart GH70

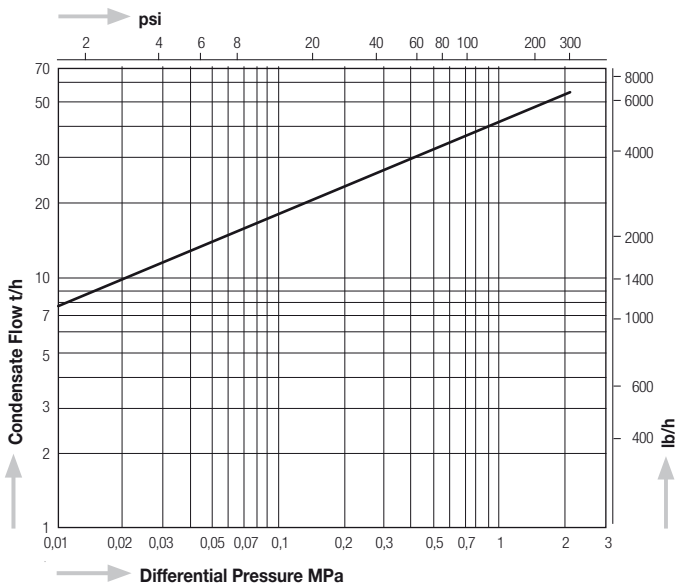

Dimensions GH60

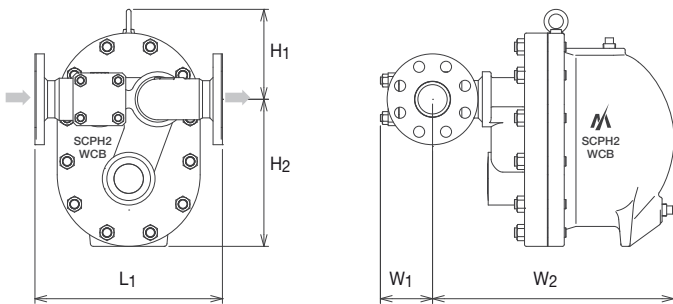

Dimensions GH70

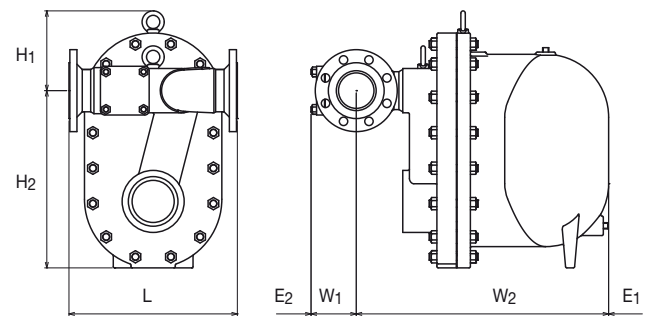

Model	Connections	Size in	Max. Operating Pressure, PMO		Max. Differential Pressure, PMX		Max. Operating Temperature, TMO		Dimensions (mm)								Dimensions (in)				Body Material	Weight	
			MPa	psig	MPa	psig	°C	°F	L	L1	H1	H2	W1	W2	E1	E2	L	L1	H1	H2		W1	W2
GH60 -2F	Flanged JIS, ASME, DIN	2" - 2½"	0,2	29	0,2	29	400	752	320	155	250	90	410			12.6	6.1	9.8	3.5	16.1	Cast Steel SCPH2	75	165
GH60 -6F			0,6	87	0,6	87																	
GH60 -10F			1,0	145	1,0	145																	
GH60 -21F			2,1	305	2,1	305																	
GH70 -21F	Flanged JIS, ASME, DIN	3" (DN80)	2,1	305	2,1	305	400	752	380	180	400	105	570	330	120	15.0	7.1	15.7	4.1	22.4	Cast Steel SCPH2	160*	352*
		4" (DN100)																				164*	352*