



**INSTALLATION - MAINTENANCE MANUAL
RF15 and RF30 Series
150 and 300 Lb. Flanged One piece Ball Valves**

DESIGN

The design features of this valve include a one piece construction body which results in simplified maintenance and trouble free operation. These valves feature a "free floating" ball. The ball is not fixed, but is free to move with the line pressure. As a result of this feature, these valves are capable of tight shut-off with flow in either direction or dead-ended, regardless of the position of the valve in the line.

The downstream seat, opposite the pressurized side of a closed valve, must carry the load exerted by the line pressure on the ball, while the upstream seat is subject to little load or wear. For this reason, it is sometimes possible to increase useful seat life by turning the valve end-for-end in the pipeline.

1. USE

The valve should be maintained as part of a preventative maintenance program and in accordance with Flow-Tek's recommended pressure, temperature and corrosion limits to insure a long service life. During shipment, storage, and in operation, the valve should be fully open or fully closed ("open" is preferred for shipping and storage). Do not use in throttling service without investigating flow and pressure conditions.

WARNING: Before installing this equipment, confirm that it is suitable for the intended service.

The identifications tags describe the maximum allowable service conditions for this product.

Be sure that the installation is protected by appropriate pressure control and safety devices to insure that acceptable limits are not exceeded.

2. OPERATION:

Operation of the valve is done by turning the handle a 1/4 turn (90 degree turn). Clockwise to close, counter clockwise to open.

A. VALVE OPEN POSITION

The handle is parallel with the pipeline.

B. VALVE IN CLOSED POSITION

The handle is perpendicular to the pipeline.

Valves with actuators should be checked for actuator -valve alignment. Misalignment will result in high operational torque and damage to stem and seals.

3. STEM SEAL ADJUSTMENT

1. For 1"- 2", if slight leakage is noted at stem, straighten lock washer tab, tighten stem nut to flatten Bellville Washers, back stem nut off 1/4 turn, secure lock washer tab.
2. For sizes larger than 2", simply tighten gland bolts evenly until leak stops. Do not over tighten.

4. GENERAL INFORMATION FOR ON-SITE INSTALLATION

The valve may be fitted in any position on the pipeline.

Before installing the valves, the pipes must be flushed clean of dirt, burrs, and welding residues, or the seats and ball surface will be damaged.

5. DISASSEMBLY AND CLEANING PROCEDURE

CAUTION: Line must be depressurized before disassembly. Valve should be cycled to assure there is no pressure is trapped in valve cavity. Ball valves can trap pressurized media when closed. Flush line with valve 1/2 open to remove hazardous media. Valve should be cycled to assure there is no pressure in the valve body cavity.

Warning: DONOT remove packing gland or any other valve parts while line is under pressure!

1. If the valve has been used to control hazardous media, it must be decontaminated before disassembly. It is recommended that the following



steps are taken for safe removal and reassembly.

2. As shipped from the factory, valves contain a Silicone based lubricant. This is for break-in and may be removed, if it is objectionable for a particular application, by disassembling and solvent washing.

Stem seal leakage may be corrected without disassembly by tightening the packing gland nut until such leakage stops. If the leakage continues or valve operating torque becomes excessive, the seals are worn and replacement will be necessary.

If the valve has been used to control hazardous media, it must be decontaminated before disassembly.

It is recommended that the following steps be taken for safe removal and assembly.

As shipped from the factory, Valves contain Silicone based lubricant. This is for break-in and may be removed by disassembly and solvent washing.

6. DISASSEMBLY

Stem seal leakage may be corrected without disassembly. Tighten the packing gland nuts until leakage stops. If leakage continues or valves operating torque becomes excessive, the seals are worn and replacement will be necessary.

Warning: DO NOT remove packing gland or any other valve parts while line is under pressure! Under no circumstance! Line must be depressurized before disassembly.

- A. Remove valve from line and clamp in vise with handle and removable body insert in an accessible position.
- B. Put ball in the OPEN position. Insert spanner wrench into slot in the retainer and rotate the counter-clockwise.
- C. Remove body seal from body. Use caution to prevent damage to metal parts; discard seal.
- D. Turn handle to CLOSED position so that the stem tang and ball slot are in line with the port opening. Lift or roll ball out of insert end.

- E. If stem seals are to be replaced, remove handle retainer nut, stop plate and packing gland. Push stem into valve cavity and remove from retainer end.
- F. Remove seats from insert and body cavity, remove stem seals.

7. VISUAL INSPECTION:

Clean and inspect metal parts. It is not necessary to replace the ball and stem unless the seating surfaces have been damaged by abrasion or corrosion. Replacement of all soft parts whenever the valve is disassembled for reconditioning is strongly recommended. This is the surest protection against subsequent leakage after valve assembly. The replacement parts can be ordered in kit form.

NOTE: The valve may be assembled and operated dry where no lubricants are allowed in the system; however, a light lubrication of mating parts will aid in assembly and reduce initial operating torque. Lubricant used must be compatible with the intended line fluid.

8. ASSEMBLY:

1. Install one seat in the body cavity with the spherical curvature facing the ball.
2. Install thrust washer on stem and slide the stem up through the body. Install packing and packing gland with packing gland bolt.
3. Install stop plate, handle and handle nut.
4. Turn the handle to the CLOSED position. Line up the ball slot with the stem tang and slide the ball into position.

Open the valve to hold the ball in place.

5. Install the remaining seat in the insert with the spherical curvature facing the ball. Install body gasket.
6. Carefully center the insert and press down until the threads are engaged. Start the threads clockwise by hand tightening with the tool used for removal. The end cap should be tightened until the end cap is flush with the flange face. The insert bottoms out in a metal to metal fit.



7. Cycle the valve slowly, with a gentle back and forth motion, to build gradually to the full quarter turn. By cycling slowly, the seat lips will assure a permanent seal shape against the ball. A fast turning motion, at this point, may cut the seats before they have a chance to form the proper seal.
8. If a tester is available, pressure test valve prior to reinstallation.

9. TEST AS FOLLOWS:

Test valve, if possible, prior to placing valve back into line position. **WARNING: If not properly secured, the valve can separate from the pressure source, resulting in possible injury. Always join the valve to companion flanges of same pressure rating as valve and secure with a full set of flange bolts.**

1. Secure valve to a test future by means of a mating flange with full bolting and a suitable gasket. Orient valve so seat to be tested is facing up.

2. Introduce 50 to 100 psig air. Partially cycle the valve, under pressure, and then slowly close to make sure the cavity is pressurized (use hearing protection). Pour water into the upper port to cover the ball and visually check for bubbles. If bubbles appear, pour the water out, cycle the valve several times and recheck. To check for leakage in the other port, reverse the valve and introduce air pressure to the port just checked.
3. Check the stem seal at this time by coating the gland area with a soapy water solution. If leakage occurs, tighten stem seal just until leakage stops.

1" - 2" Valves

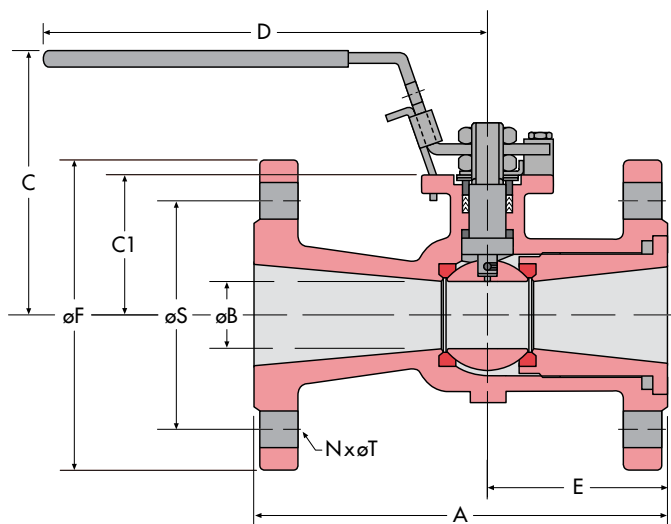

Dimensions may be found in product literature

3"-12" Valves

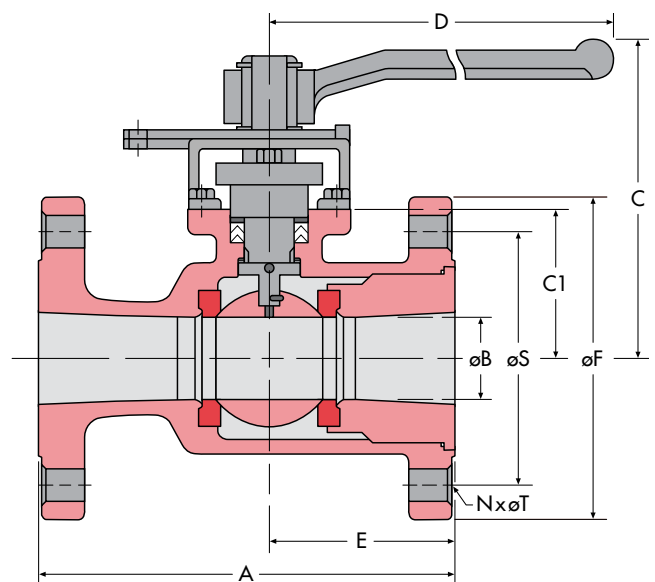



1" – 2" Valves

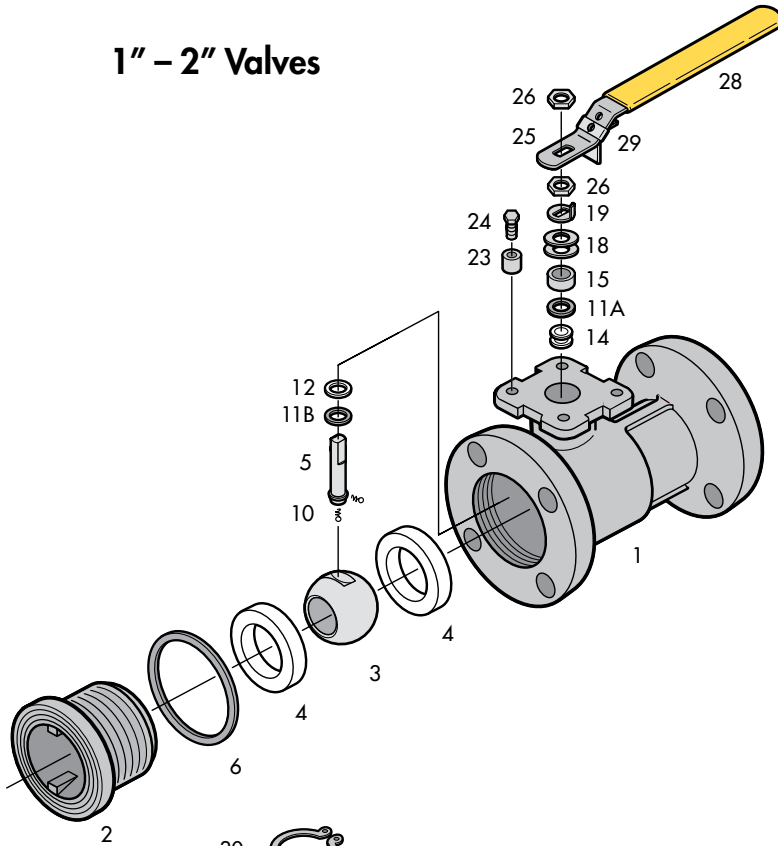

3" – 12" Valves

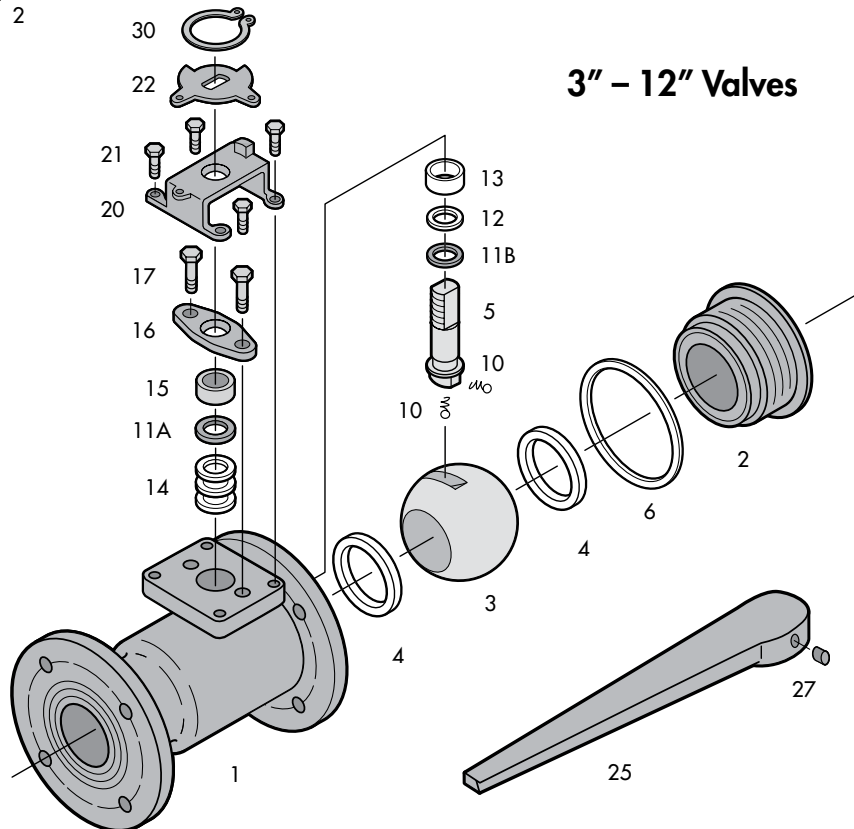

COMPONENTS

| Item | Name |
|------|------------------------|
| 1 | Body |
| 2 | End Cap |
| 3 | Ball |
| 4 | Seat |
| 5 | Seat Support |
| 6 | Body Seal* |
| 10 | Anti-Static Device |
| 11A | Packing Protector* |
| 11B | Washer Protector* |
| 12 | Thrust Washer* |
| 13 | Stem Bearing* |
| 14 | Stem Packing* |
| 15 | Packing Gland Sleeve |
| 16 | Packing Gland Plate |
| 17 | Gland Bolt |
| 18 | Belleville Washer |
| 19 | Tab Washer |
| 20 | Travel Stop Housing |
| 21 | Housing Bolt |
| 22 | Travel Stop |
| 23 | Travel Stop Set Sleeve |
| 24 | Travel Stop Bolt |
| 25 | Handle |
| 26 | Lock Nut |
| 27 | Handle Bolt |
| 28 | Handle Sleeve |
| 29 | Locking Device |
| 30 | Snap Ring |

* Parts included in repair kit



9. Short and Long Term Storage:

Short term:

1. Short term storage is defined as storage of products and equipment to be used in the construction of a project for periods of one to three months.
2. Ball valves should remain in the original shipping containers be placed on pallets of wood or other suitable materials. End protectors should remain on the valve ends to prevent the entrance of dirt.
3. Valves should be stored in the open position to protect the ball and seats.
4. Storage of ball valves can be in an open uncovered area provided provisions are made for inclement weather such as tarps or sheeting. Valves with electric actuators shall be stored under cover until ready for installation.

Long term:

1. Long term storage is storage of products and/or equipment for periods of three months or more.
2. Valves should be stored in the open position to protect the ball and seats.
3. Ball valves should remain in the original shipping containers placed on pallets of wood or other suitable materials and stored indoors. End protectors should remain on the valve ends to prevent the entrance of dirt. The storage environment should be dry and not have severe swings in temperature and humidity.